

# TOWER TRAINER™ 60 MKII

ALMOST-READY-TO-FLY RADIO CONTROLLED MODEL AIRPLANE

ASSEMBLY INSTRUCTIONS

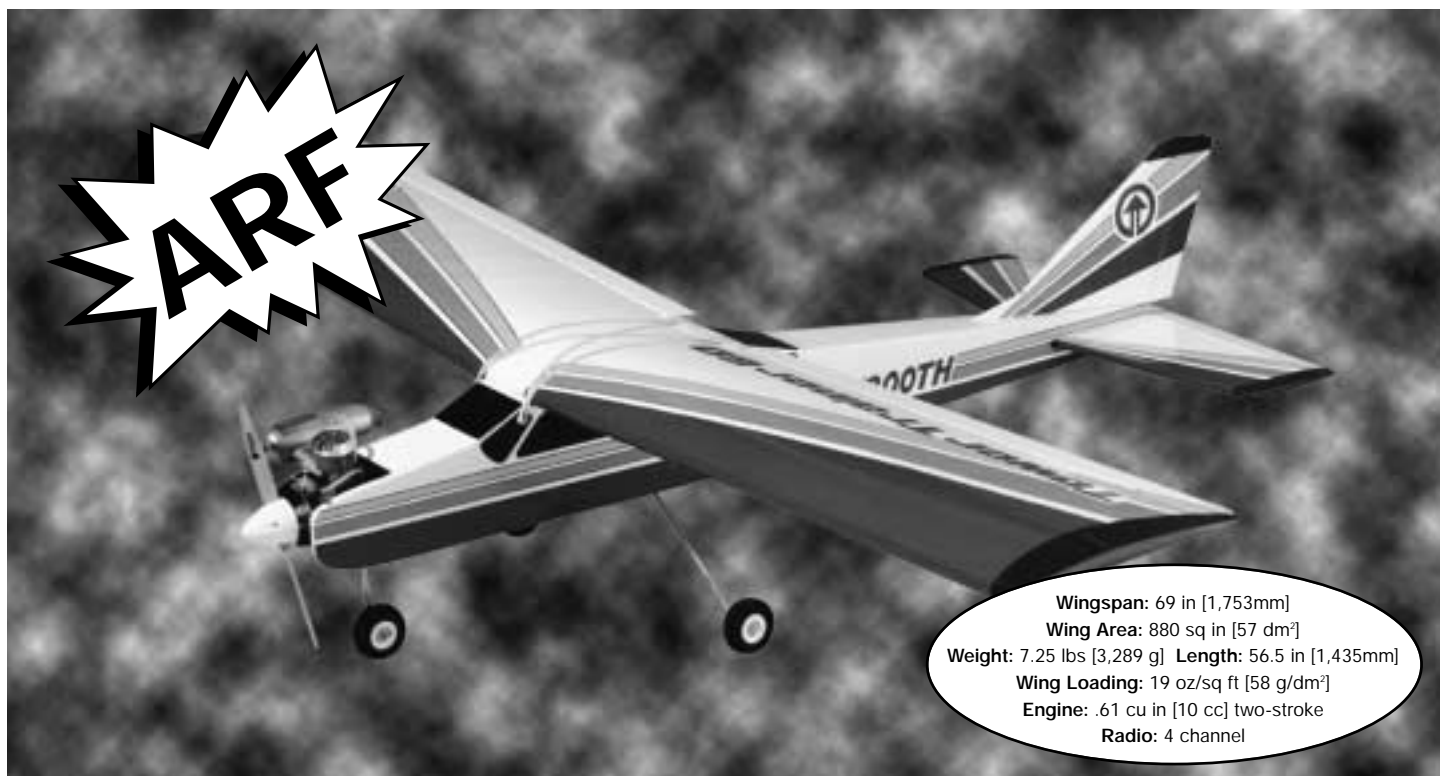

## WARRANTY

Tower Hobbies® guarantees this kit to be free from defects in both material and workmanship at the date of purchase. This warranty does not cover any component parts damaged by use or modification. **In no case shall Tower Hobbies' liability exceed the original cost of the purchased kit.** Further, Tower Hobbies reserves the right to change or modify this warranty without notice.

In that Tower Hobbies has no control over the final assembly or material used for final assembly, no liability shall be assumed nor accepted for any damage resulting from the use by the user of the final user-assembled product. By the act of using the user-assembled product, the user accepts all resulting liability.

**If the buyer is not prepared to accept the liability associated with the use of this product, the buyer is advised to return this kit immediately in new and unused condition to the place of purchase.**

**READ THROUGH THIS MANUAL COMPLETELY BEFORE STARTING CONSTRUCTION. IT CONTAINS IMPORTANT INSTRUCTIONS AND WARNINGS CONCERNING THE ASSEMBLY AND USE OF THIS MODEL.**



Tower Hobbies  
P.O. Box 9078  
Champaign, IL 61826  
(800) 637-6050  
[www.towerhobbies.com](http://www.towerhobbies.com)

## TABLE OF CONTENTS

INTRODUCTION .....	2
SAFETY PRECAUTIONS .....	2
ADDITIONAL ITEMS REQUIRED .....	3
ENGINE RECOMMENDATIONS.....	3
RADIO RECOMMENDATIONS .....	3
COVERING ACCESSORIES.....	3
ADHESIVES & ASSEMBLING SUPPLIES .....	3
OPTIONAL SUPPLIES & TOOLS .....	3
PREPARATIONS .....	3
ASSEMBLE THE WING .....	4
JOIN THE WING .....	4
HOOK UP THE AILERONS.....	6
ASSEMBLE THE FUSELAGE .....	10
MOUNT THE STAB & FIN.....	10
INSTALL THE WING MOUNTING DOWELS .....	13
INSTALL THE FUEL TANK .....	14
MOUNT THE ENGINE .....	15
MOUNT THE LANDING GEAR .....	17
FINAL ASSEMBLY .....	19
HOOK UP THE CONTROLS.....	19
INSTALL THE RADIO GEAR .....	21
APPLY THE DECALS .....	23
GET THE MODEL READY TO FLY .....	23
CHECK THE CONTROL DIRECTIONS.....	23
SET THE CONTROL THROWS .....	24
BALANCE THE MODEL (C.G.).....	25
BALANCE THE MODEL Laterally .....	25
PREFLIGHT .....	25
IDENTIFY YOUR MODEL .....	25
CHARGE THE BATTERIES .....	25
BALANCE THE PROPELLERS.....	26
GROUND CHECK .....	26
RANGE CHECK .....	26
ENGINE SAFETY PRECAUTIONS .....	26
AMA SAFETY CODE (EXCERPTS).....	27
CHECK LIST .....	27
GETTING READY TO FLY .....	27
USING RUBBER BANDS.....	28
TAXIING.....	28
TAKEOFF .....	28
FLYING .....	28
LANDING.....	29
FUEL MIXTURE ADJUSTMENTS .....	29
MODELING TERMS & TRIVIA.....	29
PARTS LIST.....	center section

## INTRODUCTION

Thank you for purchasing our **Tower Trainer™ 60 MKII ARF**. This model has been specially created for you and other first-time radio control modelers. The Tower Trainer 60 MKII ARF offers nearly all the excitement of piloting a real airplane...and develops skills that will take you anywhere you want in your new hobby.

## PROTECT YOUR MODEL, YOURSELF & OTHERS...FOLLOW THESE IMPORTANT SAFETY PRECAUTIONS

1. Your **Tower Trainer 60 MKII ARF** should not be considered a toy, but rather a sophisticated, working model that functions very much like a full-size airplane. Because of its performance capabilities, the Tower Trainer 60 MKII ARF, if not assembled and operated correctly, could possibly cause injury to yourself or spectators and damage property.
2. You must assemble the model **according to the instructions**. Do not alter or modify the model, as doing so may result in an unsafe or unflyable model.
3. You must take time to **assemble straight, true and strong**.
4. You must use an R/C radio system that is in first-class condition, and a correctly sized engine and components (fuel tank, wheels, etc.) throughout the assembly process.
5. You must properly install all R/C and other components so that the model operates properly on the ground and in the air.
6. You must check the operation of the model before **every** flight to insure that all equipment is operating and that the model has remained structurally sound. Be sure to check clevises or other connectors often and replace them if they show any signs of wear or fatigue.
7. If you are not already an experienced R/C pilot, you should fly the model only with the help of a competent, experienced R/C pilot.

We, as the kit manufacturer, provide you with a top quality kit and instructions, but ultimately the quality and flyability of your finished model depends on how you assemble it; therefore, we cannot in any way guarantee the performance of your completed model, and no representations are expressed or implied as to the performance or safety of your completed model.

**Remember: Take your time and follow the instructions to end up with a well-built model that is straight and true.**

If you have not flown this type of model before, we recommend that you get the assistance of an experienced pilot in your R/C club for your first flights. If you're not a member of a club, your local hobby shop has information about clubs in your area whose membership includes experienced pilots.

In addition to joining an R/C club, we strongly recommend you join the AMA (Academy of Model Aeronautics). AMA membership is required to fly at AMA sanctioned clubs. There are over 2,500 AMA chartered clubs across the country. Among other benefits, the AMA provides insurance

to its members who fly at sanctioned sites and events. Additionally, training programs and instructors are available at AMA club sites to help you get started the right way. Contact the AMA at the address or toll-free phone number below:

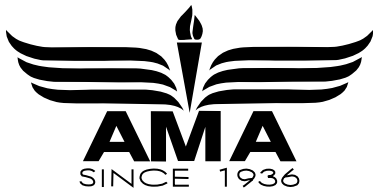

### Academy of Model Aeronautics

5151 East Memorial Drive  
Muncie, IN 47302-9252  
Tele. (800) 435-9262  
Fax (765) 741-0057  
Or via the Internet at:  
<http://www.modelaircraft.org>

## ADDITIONAL ITEMS REQUIRED

This is the list of hardware and accessories required to finish the Tower Trainer 60 MKII ARF. Order numbers are provided in parentheses.

### Engine Recommendations

TOWER HOBBIES 61 ABC (TOWG0161)  
O.S.<sup>®</sup> 65 LA (OSMG0065)  
O.S. 61 FX (OSMG0561)  
SUPERTIGRE<sup>®</sup> G-61 Ring (SUPG0161)  
SUPERTIGRE G-61 ABC (SUPG0181)

### Radio Recommendations

FUTABA<sup>®</sup> 4VF (FUTJ62\*\*)

### Covering Accessories

Tower Custom Sealing Iron (TOWR3250)  
Top Flite<sup>®</sup> Hot Sock<sup>™</sup> Iron Cover (TOPR2175)

## ADHESIVES & ASSEMBLING SUPPLIES

In addition to common household tools and hobby tools, this is the “short list” of the most important items required to assemble the Tower Trainer 60 MKII ARF. **Tower Hobbies Build-it<sup>™</sup> CA and Epoxy glue are recommended.**

- 2 oz. Tower Hobbies Build-it CA (TOWR3800)
- 30-Minute Tower Hobbies Build-it Epoxy (TOWR3811)
- 6-Minute Tower Hobbies Build-it Epoxy (TOWR3807)
- Hobby Knife (HCAR0105), #11 Blades (HCAR0211)
- Small T-pins (HCAR5100)
- Builder's triangle (HCAR0480)
- Small Phillips and flat blade screwdrivers
- Small metal file
- Pliers with wire cutter (HCAR0630)

- Threadlocker (GPMR6060)
- RTV Silicone
- Great Planes<sup>®</sup> Easy-Touch<sup>™</sup> Bar Sander (GPMR6170)
- Easy-Touch Sandpaper, 180 Grit (GPMR6184)

## OPTIONAL SUPPLIES & TOOLS

Here is a list of optional tools mentioned in the manual that will help you assemble the Tower Trainer 60 MKII ARF.

- Great Planes CG Machine<sup>™</sup> (GPMR2400)
- Top Flite Precision Magnetic Prop Balancer<sup>™</sup> (TOPQ5700)
- Masking Tape (TOPR8018)
- Epoxy Brushes (GPMR8060)
- Mixing Sticks (GPMR8055)
- Denatured Alcohol (for epoxy clean up)
- Non-elastic monofilament or Kevlar fishing line (K&SR4575)
- Builder's Triangle Set (HCAR0480)
- Masking Tape (TOPR8018)
- Felt-Tip Marker (TOPQ2510)
- Hobbico Servo Horn Drill (HCAR0698)
- Great Planes AccuThrow<sup>™</sup> Deflection Gauge (GPMR2405)

## PREPARATIONS

○ 1. Remove the major parts of the kit from the box (wings, fuselage, tail parts, etc.) and inspect them for damage. If any parts are damaged or missing, contact Product Support at the address or telephone number listed in this manual.



○ 2. Remove the masking tape and separate the ailerons from the wing, the rudder from the fin and the elevator from the stab. Where necessary, use a covering iron with a Hot Sock<sup>™</sup> Iron Cover to tighten the covering that may have loosened during storage or from removing the masking tape. Apply pressure over sheeted areas to **thoroughly** bond the covering to the wood.

## ASSEMBLE THE WING

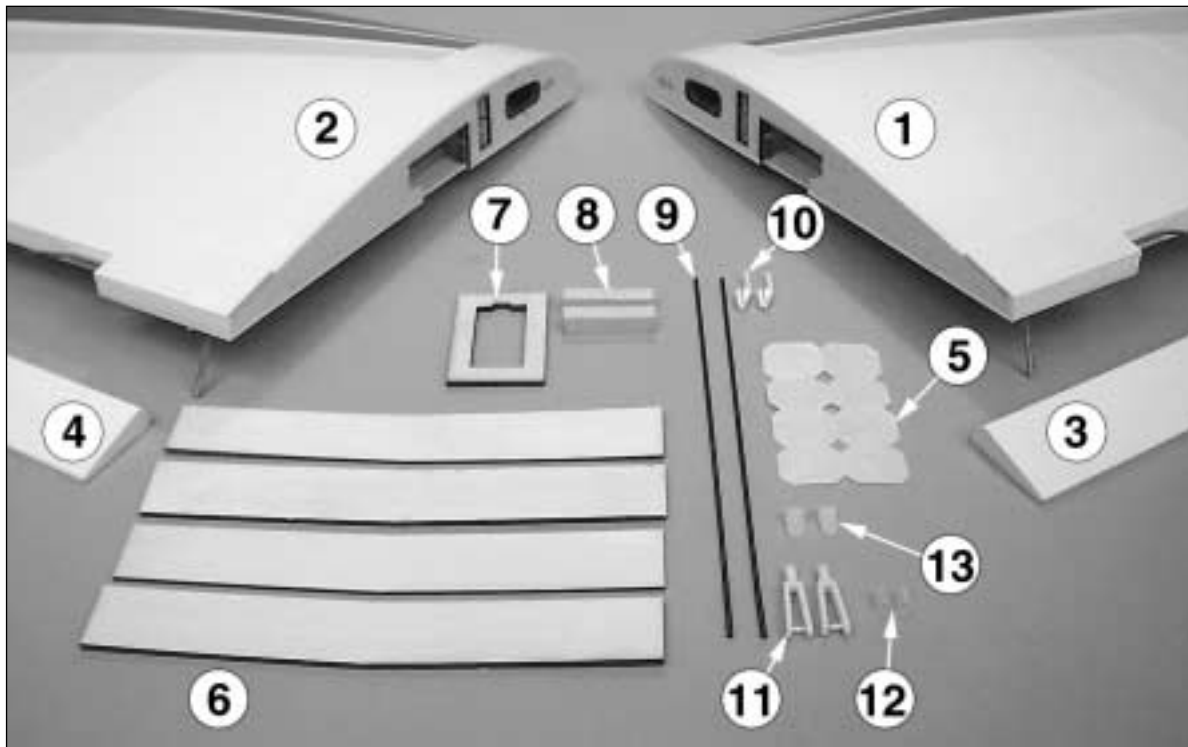

○ 1. In order to assemble the wing you will need the following items as shown in the photo above.

- #1 Right Wing Panel (1)
- #2 Left Wing Panel (1)
- #3 Right Aileron (1)
- #4 Left Aileron (1)
- #5 CA Hinges (8)
- #6 Wing Joiners (4)
- #7 Aileron Servo Tray (1)
- #8 Aileron Servo Tray Mounting Blocks (2)
- #9 Aileron Pushrods (2)
- #10 Faslinks (2)
- #11 Clevises (2)
- #12 Silicone Clevis Retainers (2)
- #13 Nylon Torque Rod Horns (2)

## JOIN THE WING

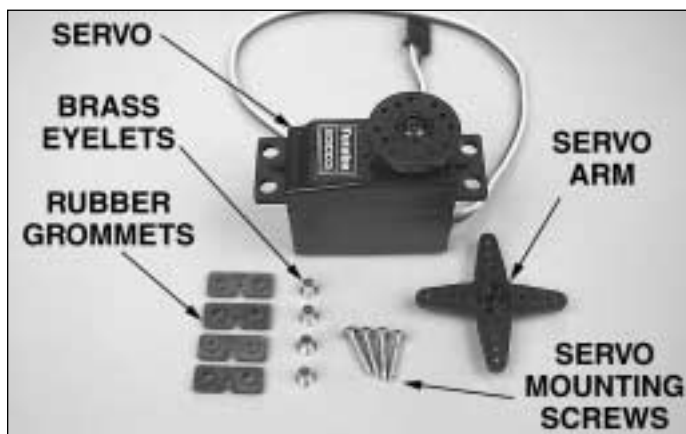
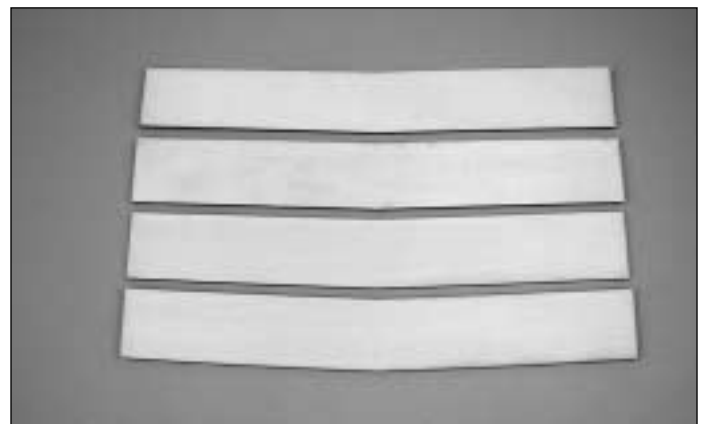

○ 2. In order to assemble the wing you will need the items shown in the photo above from your radio control system contents.

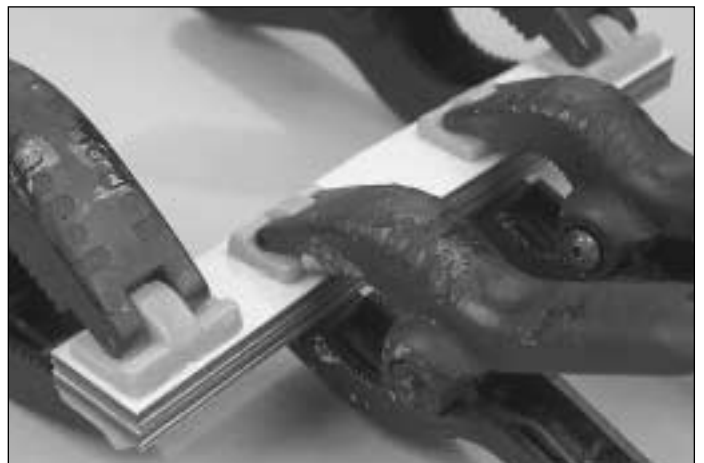

○ 3. Use 6-minute epoxy to glue the four 3mm plywood **wing joiners** together. Use weights or clamps to hold the joiners in place until the epoxy cures.



○ 4. Test fit the aileron servo in the 3mm plywood **aileron servo tray**. If necessary, trim the opening in the tray to accommodate the servo. Once you are satisfied with the fit of the servo, remove it from the tray and set it aside for now.

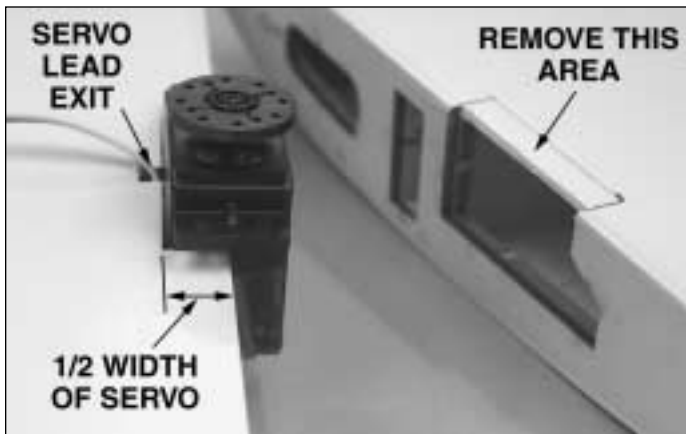

○ 5. Measure the width of your servo. Mark and cut 1/2 of this distance from the sheeting over the aileron servo mounting area in the wing panel to accommodate 1/2 of your aileron servo on each wing panel as shown in the photograph above. Remove a small area of the sheeting along side the servo as shown in the right wing panel to allow the servo lead to exit the wing when the servo is mounted in place.



○ 6. The servo will be centered in the wing after the two panels are joined. Test fit the servo into the cutout of both the wing panels. Trim the root rib if necessary to accommodate the servo and the servo wire. Check the left wing panel in the same way.



○ 7. Trim the covering from the ends of the root ribs on both wing panels. This is easily done with a sanding block and medium-grit sandpaper as shown. Trim both wing panels at this time.

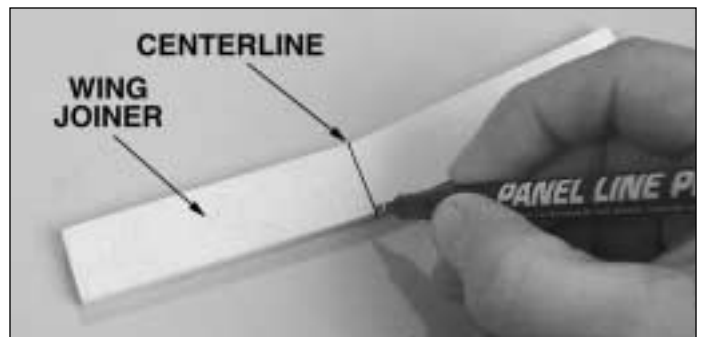

○ 8. Draw a centerline on both sides of the assembled plywood wing joiner as shown.

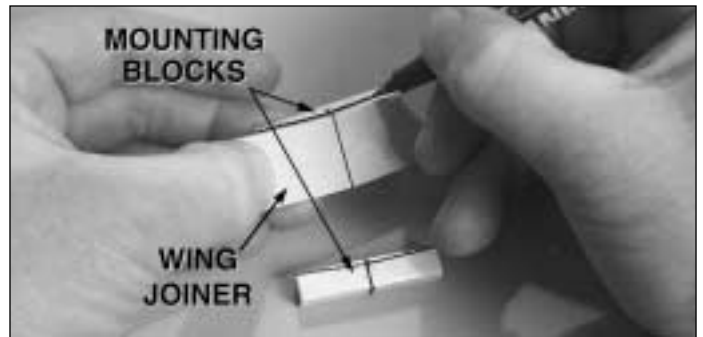

○ 9. Locate the two 8mm square x 38mm **aileron servo tray mounting blocks**. Mark a centerline on each block. Using the wing joiner as a guide, mark the wing dihedral angle on both of the aileron mounting blocks. Trim and sand to shape at this time.

**Set the blocks aside for now.**

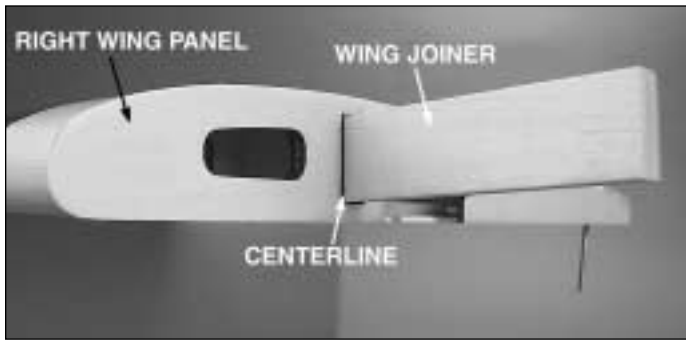

○ 10. Test fit the wing joiner into one wing panel, then the other. Be certain the joiner is installed upright with the joiner angled upward for wing dihedral. Also make sure that the joiner slides in all the way to the centerline. Test fit the wing panels together with the joiner. Make certain both panels fit well.

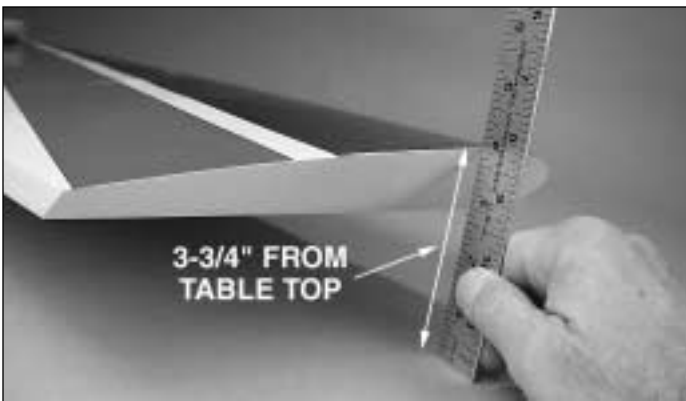
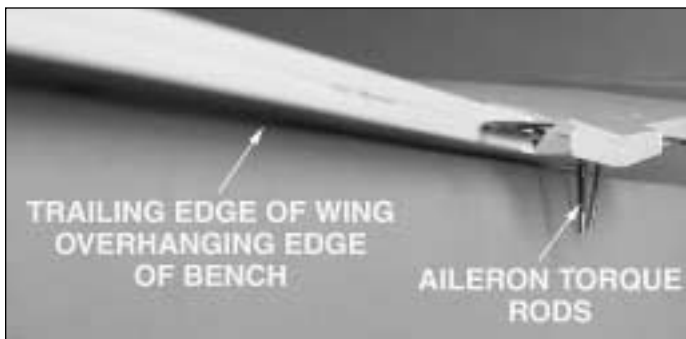

○ 11. The measurement for this wing is 3-3/4" [95mm] plus/minus 1/8" [3mm] from the top of your table to the highest point of the wing tip as shown in the photo. To check that this is correct, join the two wing panels together with the joiner in place.

Lay the wing on a flat surface with one panel flat on your bench or table. To do this you will need to allow the trailing edge of the wing to overhang the edge of your table in order to avoid the aileron torque rods as shown in the photograph above. After making sure the root ribs are fitting together with no gaps on the top or bottom of the wing, measure the distance from the surface of the table to the wing tip. If this measurement is not 3-3/4" [95mm] plus/minus 1/8" [3mm] make adjustments in the plywood joiner. (It is possible that the joiner may require slight sanding to remove slivers of wood or excess epoxy that may interfere with the fit).

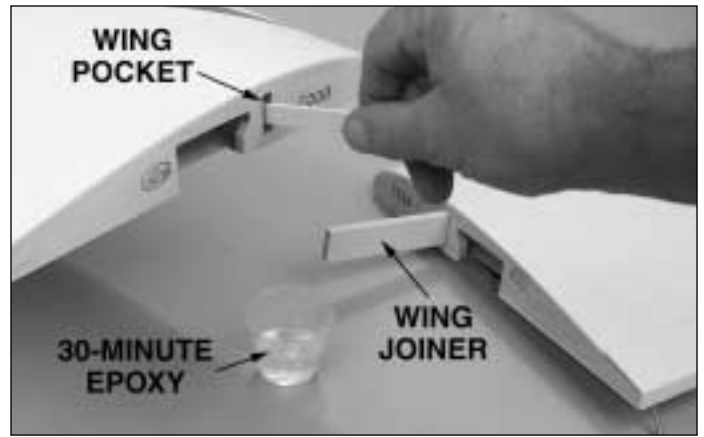

○ 12. Once satisfied with the fit of the joiner and the wing has the proper dihedral, it is time to glue the two panels together. First **thoroughly** coat the inside of both pockets where the joiner fits and one half of the joiner with 30-minute epoxy. Making certain the joiner is upright, insert the coated end into one of the wing panels. Coat the other end of the joiner and both wing root ribs with the epoxy and join the two wing panels together.

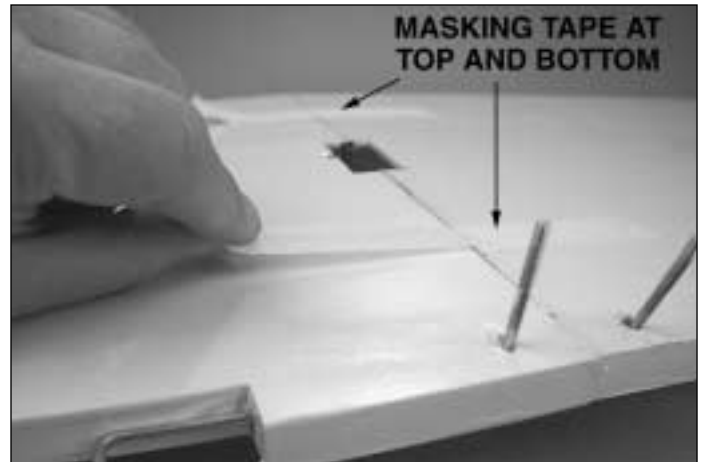

○ 13. Wipe away epoxy that squeezes out from between the wing halves with paper towels saturated with alcohol. Use masking tape on the top and bottom to hold the wing together as shown. Be certain the root ribs on the ends of the wing panels accurately align. Again, wipe away excess epoxy and do not disturb the wing until the epoxy has fully hardened.

## HOOK UP THE AILERONS

Do the left wing first so the assembly matches the photographs the first time through. You can do one wing at a time, or work on them together.

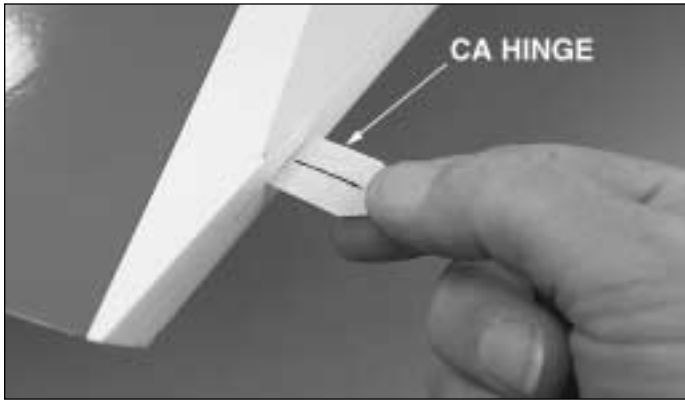

○○ 1. Take a close look at the supplied hinges. The above photo has this slot highlighted and must be inserted into place in the proper direction as indicated in the photo.

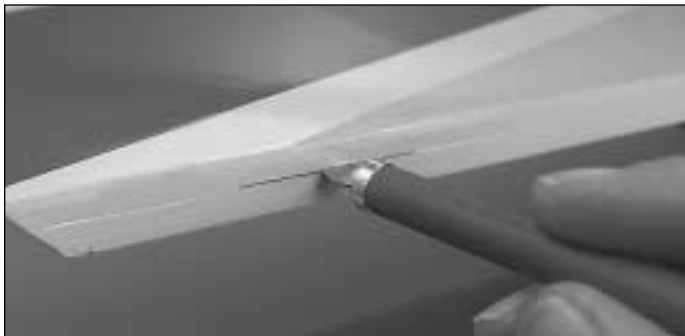

○○ 2. Test fit the hinges in the hinge slots of the **aileron** and the **wing**. If you have difficulty inserting the hinges, insert a #11 blade into the slot and **carefully** move it back and forth to slightly widen the slot. Test fit the aileron to the wing with the hinges.

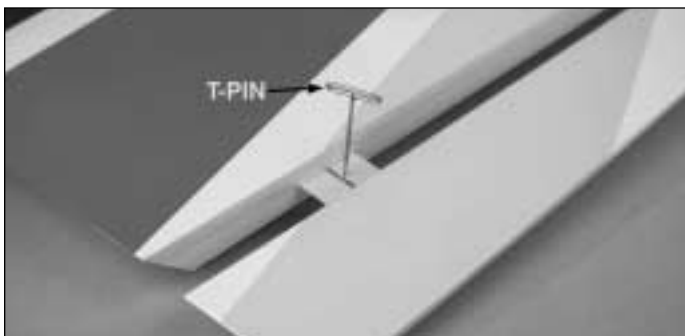

○○ 3. If the hinges don't remain centered, stick a pin through the middle of the hinge to hold it in position as shown.

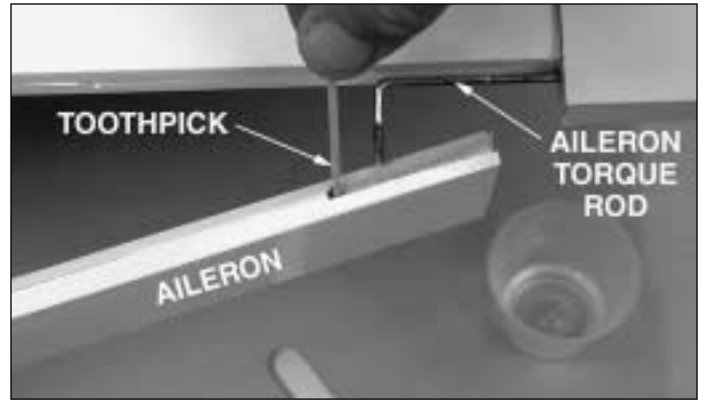

○○ 4. Coat the "arm" portion of the **aileron torque rod** that slips inside the aileron and the groove, and the hole in the aileron where the torque rod fits, with 30-minute epoxy. **Tip:** You may want to use a toothpick to get epoxy into the hole drilled in the aileron for the aileron torque rod "arm."

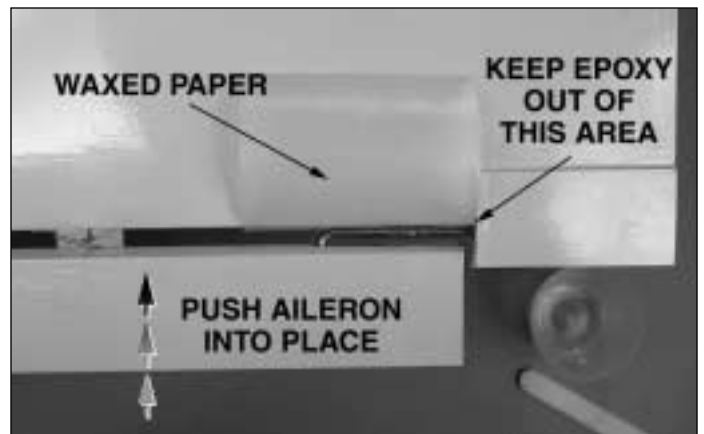

○○ Use a strip of waxed paper between the torque rod and the wing to keep from gluing the torque rod to the wing. Be careful to keep the epoxy out of the area where the rod enters the trailing edge of the wing. Place a small amount of petroleum jelly in this area. Join the aileron to the wing and the torque rod with the hinges. Wipe away excess epoxy with a tissue saturated with alcohol.

○○ 5. Remove the T-pins if you've used any. Adjust the aileron so there is a **small** gap—just enough to see light through or to slip a piece of paper through—between the aileron and the wing.



○○ 6. Apply six drops of **thin** CA to the top and bottom of each hinge. Do not use CA accelerator. After the CA has fully hardened, test the hinges by pulling on the aileron. Go back and install the other aileron in the same manner.

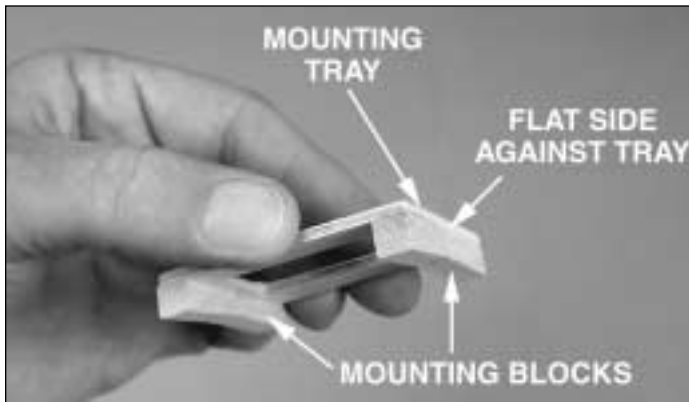

○ 7. Glue the two 8mm square x 38mm aileron servo tray mounting blocks that you cut to shape earlier to the aileron servo tray. Be sure that you glue the flat side of the blocks to the aileron servo mounting tray.

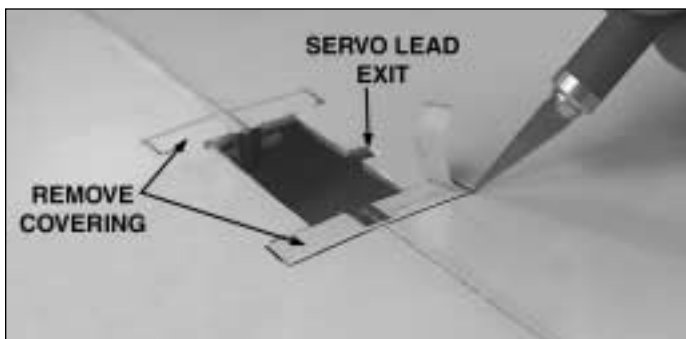

○ 8. Place the servo into this assembly and test fit this into location in the center of the wing. Mark the location of the mounting blocks with a felt-tipped pen.

Use a sharp #11 blade to cut the covering from the wing for the aileron servo mount. Be extremely careful to cut only the covering and do not cut into the balsa wood under the covering.

## Expert Tip

### How to cut covering from balsa.

To avoid cutting into the balsa, use a soldering iron instead of a hobby knife to cut the covering from the stab. The tip of the soldering iron doesn't have to be sharp, but a fine tip does work best. Allow the iron to heat fully. Use a straightedge to guide the soldering iron at a rate that will just melt the covering and not burn into the wood. The hotter the soldering iron, the faster it must travel to melt a fine cut. Peel off the covering.

Be sure to place the aileron servo lead in the cut out you made in an earlier step. Glue the servo mount to the wing with 6-minute epoxy.

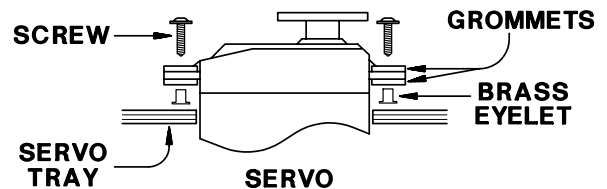

○ 9. Assemble the servo using the four servo grommets and four brass eyelets as shown in the sketch above. Insert the servo into the mount and mark the location for the 4 screws. Remove the servo and drill 1/16" [1.6mm] holes through the servo mount for the servo mounting screws.

Run the servo mounting screws into the mount and then remove them, which will make threads in the wooden servo mount. Add a drop of thin CA to the holes and allow to fully harden, thus hardening the threads for more strength. **Note:** Do not apply the thin CA with the servo in place as you will glue it to the mount. Mount the aileron servo using the servo mounting screws.

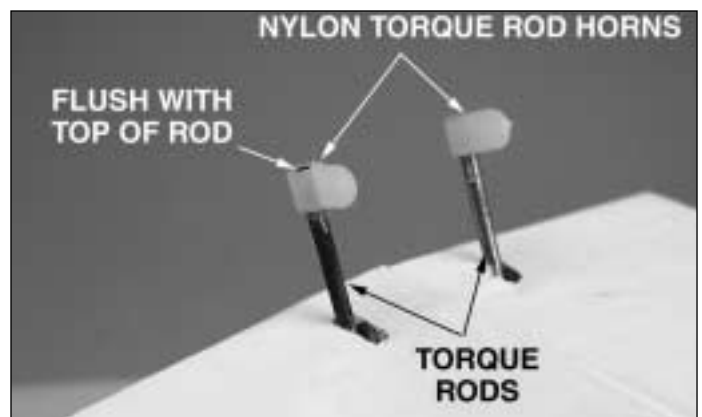

○ 10. Thread **nylon torque rod horns** onto both aileron torque rods until the top of the horn is even with the top of the torque rod as shown in the photograph.

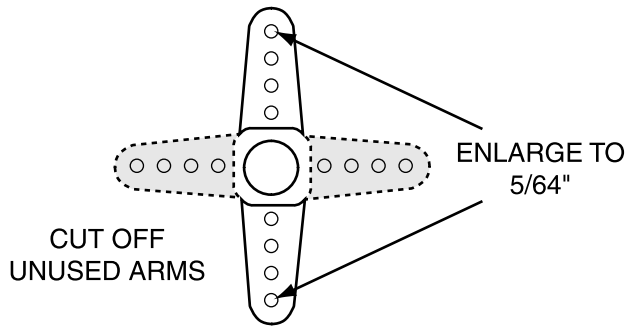

○ ○ 11. Make a two-arm **servo arm** by cutting two arms off a four-arm servo arm. Enlarge the outer holes in the arm with a **Hobbico Servo Horn Drill** (or a #48 or 5/64" [2mm] drill bit).

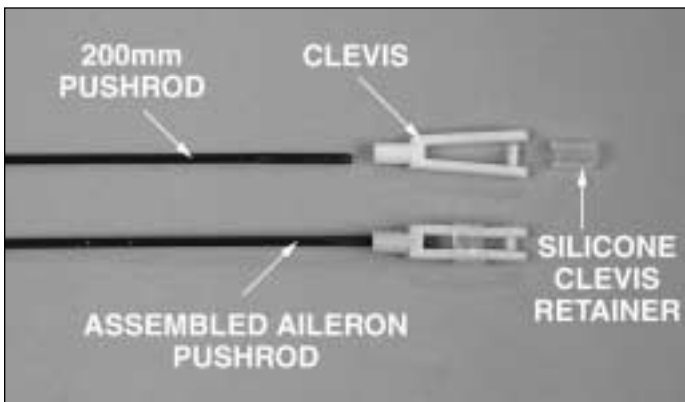

○ 12. Assemble the two **aileron pushrods** made from two 200mm wire pushrods, **clevises**, and **silicone retainers**. To make the pushrods, install the clevises onto the wire pushrods approximately 25 full turns.

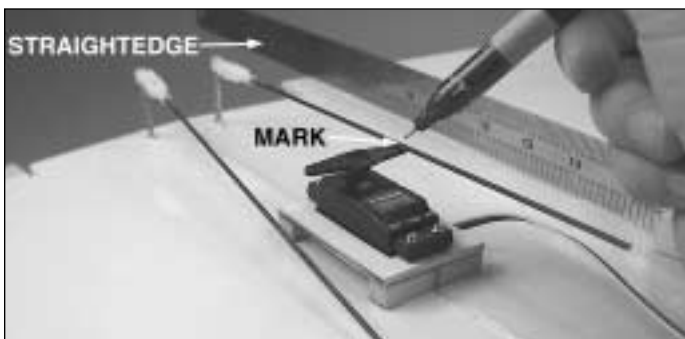

○ ○ 13. Center the servo arm on the servo. Attach the clevis to the torque rod horn; hold the aileron level with the bottom of the wing, using a straightedge to assure accuracy. Mark the location where the wire crosses the hole in the servo arm. At this location bend the wire 90 degrees.

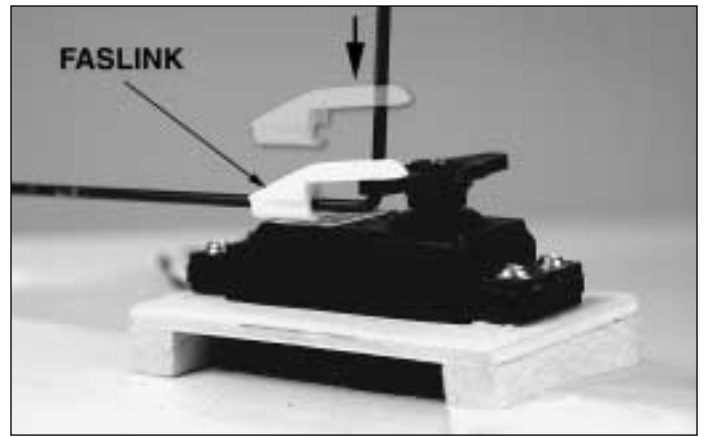

○ ○ 14. After bending the pushrods at your mark, slide the **Faslink** over the wire and snap it into place on the pushrod.

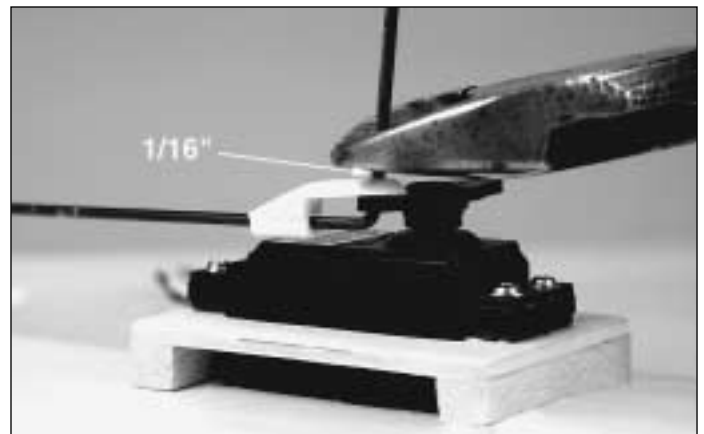

○ ○ Cut the wire that extends beyond the Faslink; be certain to leave 1/16" [1.6mm] of wire protruding from the Faslink as shown in the photograph.

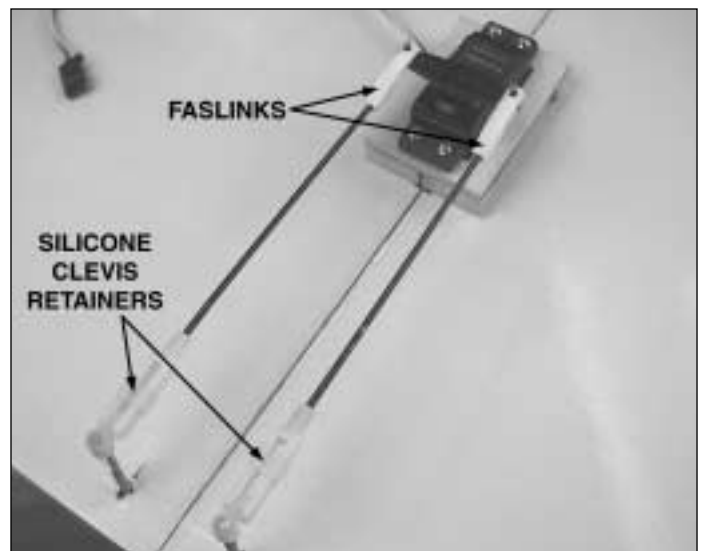

○ 15. Install the remaining pushrod in the same manner. The above photo shows how your assembly should look when finished.

# ASSEMBLE THE FUSELAGE

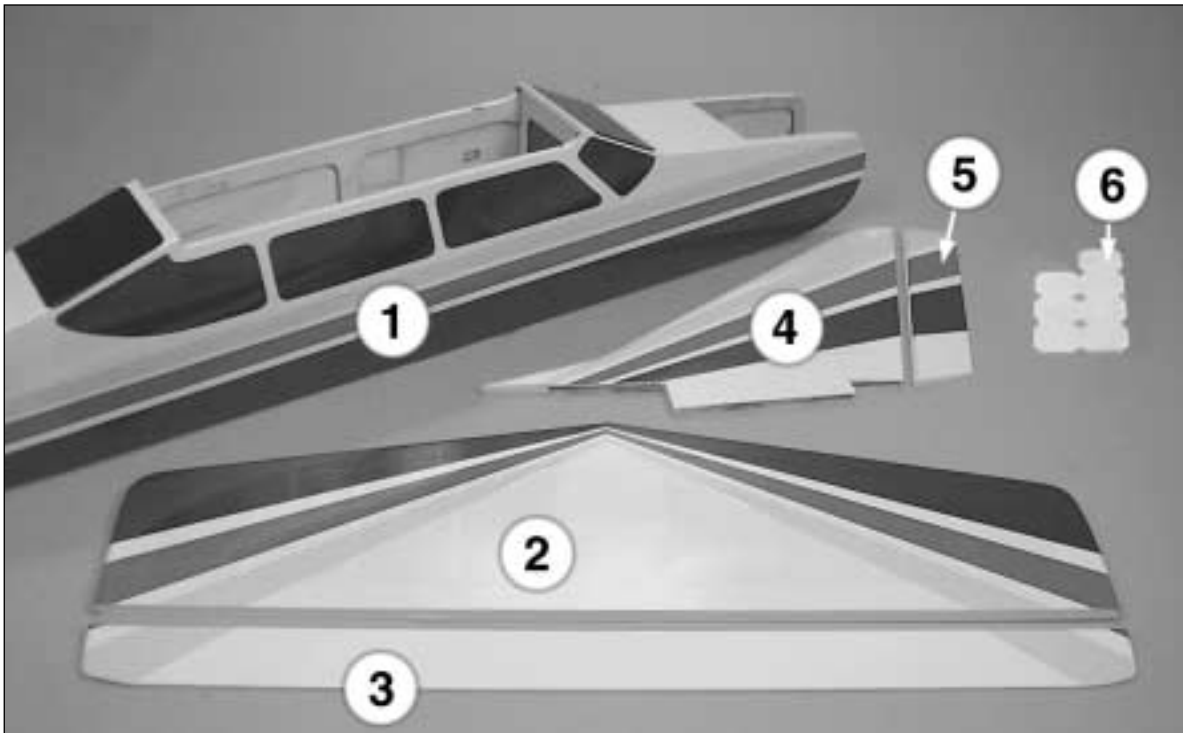

## MOUNT THE STABILIZER & FIN

○ 1. In order to complete this section you will need the following items as shown in the photograph above. You will also need the wing (not shown) for alignment purposes.

- #1 Fuselage (1)
- #2 Stabilizer (1)
- #3 Elevator (1)
- #4 Fin (1)
- #5 Rudder (1)
- #6 CA Hinges (7)

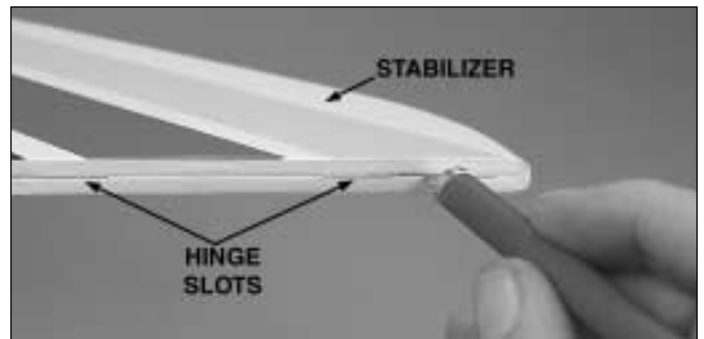

○ 2. Test fit the hinges into hinge slots in the **stabilizer** and **elevator** and the **fin** and **rudder**. If necessary insert a #11 blade into the hinge slots and run it back and forth to enlarge them slightly. **Important Note:** Remember to insert the hinges with the cut running the correct direction.

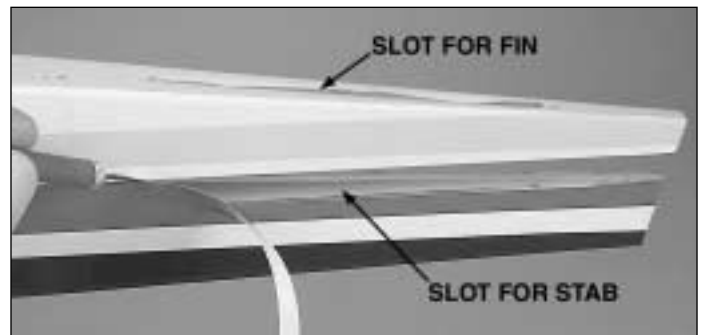
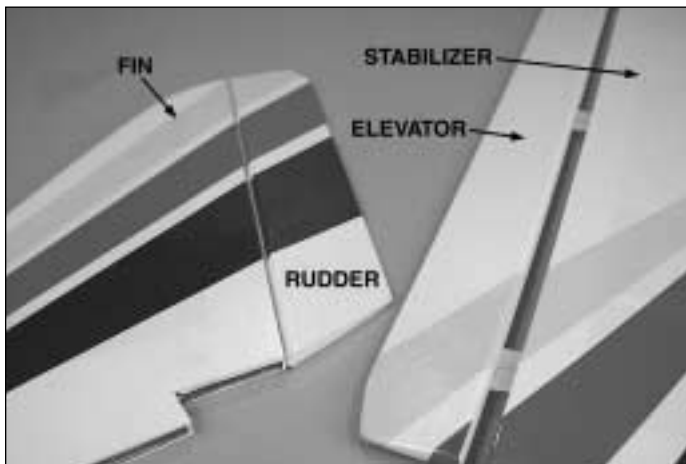

○ 3. Use a hobby knife with a sharp #11 blade and cut the covering from the openings on both sides of the fuselage for the stab. Also cut the covering from the opening in the top of the fuselage for the fin. Remove the elevator from the stab.

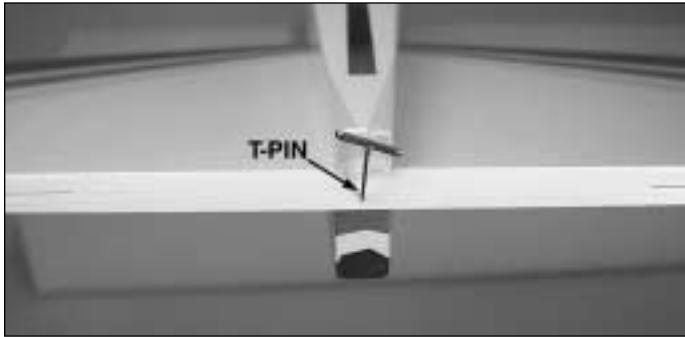

○ 4. Taking accurate measurements, locate the center of the stab along the trailing edge. Slide the stab into the fuselage and center it over the aft end of the fuselage. Insert a T-pin through the stab and into the fuse at the location shown in the photograph above. This will hold it in place but will still allow for correct alignment.



○ 5. Support the model with a small stand or cardboard box. Place the wing into the wing saddle on the top of the fuselage. Stand five to ten feet behind the model and view the stab and wing. If the stab and wing align with each other, proceed to the next step. If the stab and wing do not align, place a small weight on the "high" side of the stab to bring it into alignment. If much weight is required, remove the stab and **carefully** sand the slot in the fuselage where the stab fits until it aligns with the wing.



○ 6. Stick a T-pin into the top of the fuselage centered in the middle stringer over the firewall. Tie a small loop in one end of

a piece of **non-elastic string** (K & S #801 Kevlar thread; K&SR4575). Slip the loop in the string over the T-pin.

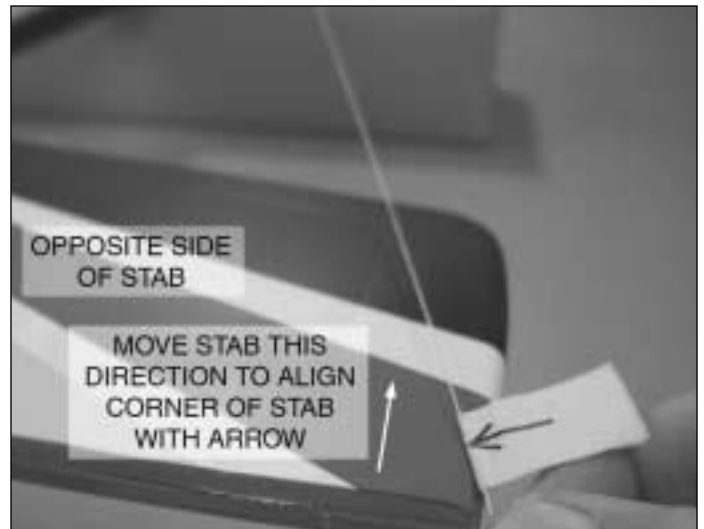
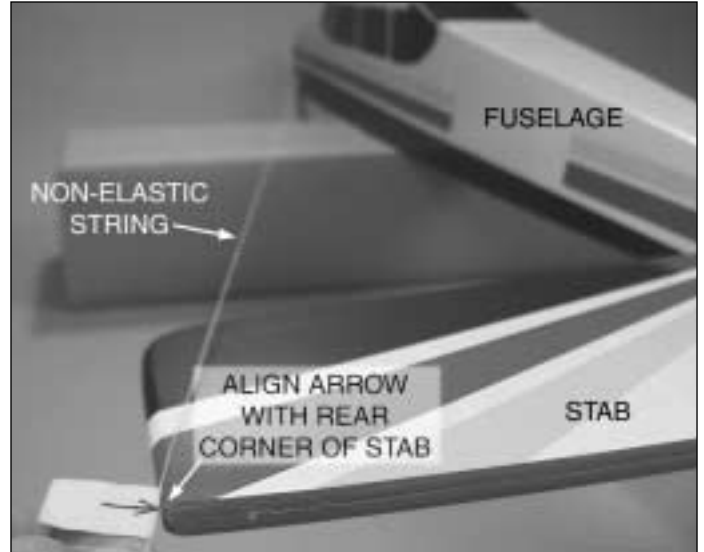

○ 7. Fold a piece of masking tape over the other end of the string and draw an arrow on it. Slide the tape along the string and align the arrow with one end of the stab as shown in the photograph. Swing the string over to the same position on the other end of the stab. If the distance is not equal move the stab 1/2 way to the arrow. Then move the string back to the other side to check alignment. Adjust the stab in this manner until both sides are equal.



○ 8. When you are satisfied with the alignment of the stab use a fine-point felt-tip pen such as a **Top Flite Panel Line**

Pen (TOPQ2510) to mark the outline of the fuselage onto the top and bottom of the stab.

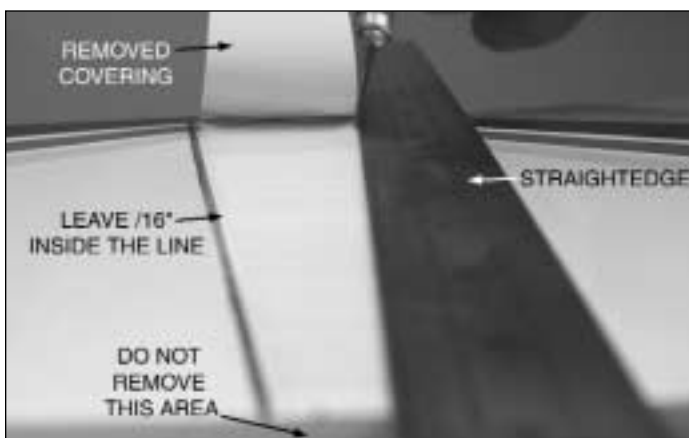

○ 9. Remove the stab from the fuselage. Use a sharp #11 hobby knife or refer to the **Expert Tip** on page 8, to cut the covering from the stab 1/16" [1.6mm] **inside** the lines you marked on the top and bottom of the stab. Do not remove the covering from the trailing edge of the stab. Use care to cut **only into the covering** and **not** into the wood. Cutting into the balsa will weaken the structure.

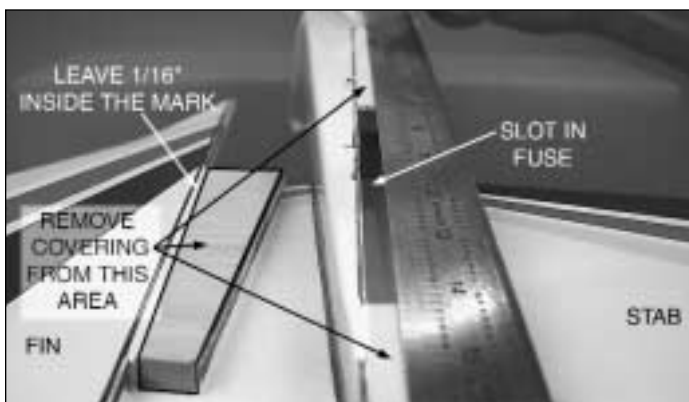

○ 10. **Note:** If you like, you may remove the rudder and elevator from the fin and stab for these steps. We will glue them into place later.

Fit the fin into the fuselage and mark the location of the fuselage onto the fin with a felt-tip pin. Also mark the

location of the fin on top of the fuselage. Using the same method as with the stab, cut the covering material from the mark on the bottom of the fin and the top of the fuselage.

○ 11. Apply **30-minute epoxy** to **all** joining surfaces of the stab. Slide the stab into position. Wipe away residual epoxy with a tissue dampened with rubbing/denatured alcohol. If the stab required a weight on one side or the other to align it with the wing, position the weight. Use the pin and string to confirm stab alignment. Do not disturb the model until the epoxy has fully hardened.

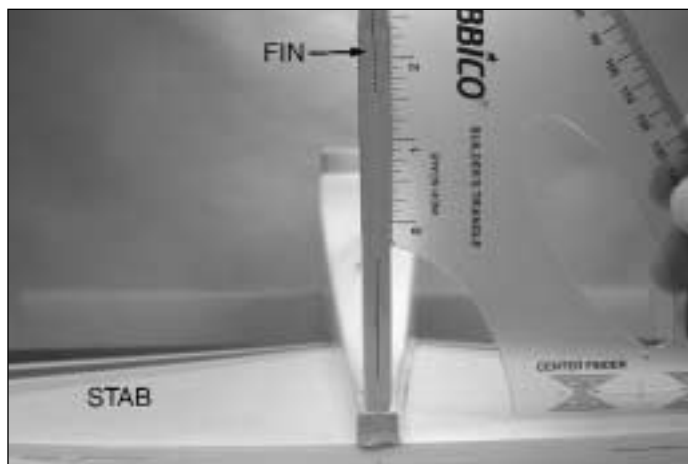

○ 12. Apply 30-minute epoxy to **all** joining surfaces of the fin. Insert the fin and wipe away excess epoxy. Use a 90° triangle to check that the fin is vertical. If necessary, use masking tape to pull the tip of the fin to one side or other of the stab until it is vertical. Do not disturb the model until the epoxy has fully hardened.

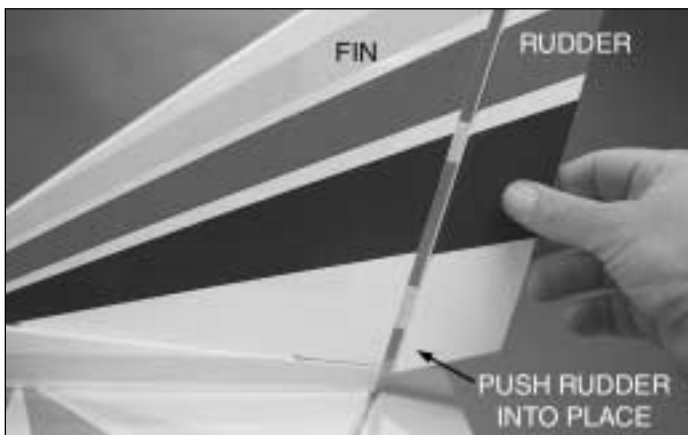

○ 13. When the epoxy has fully hardened, make sure the rudder and elevator are in the proper position with all the hinges properly installed. Place six drops of thin CA on both sides of each hinge location. Let the CA cure completely. Do not use activator. Pull on each control surface to make sure it is glued properly.

# INSTALL THE WING MOUNTING DOWELS

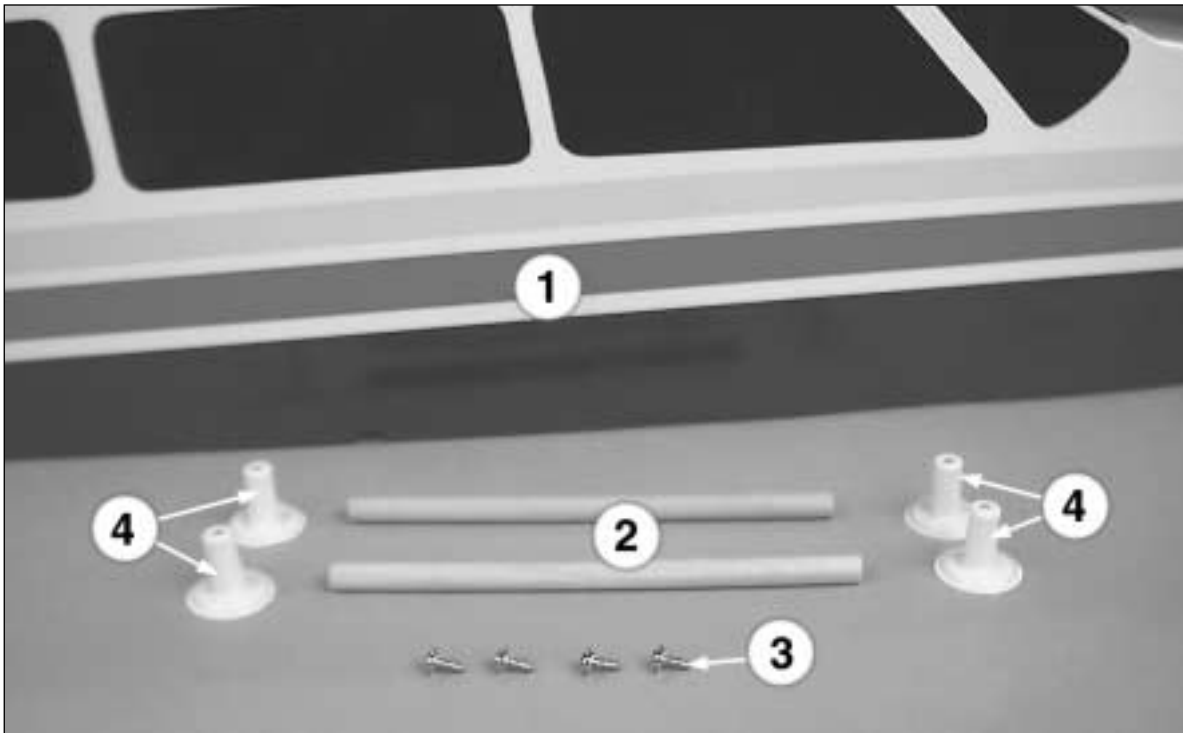

○ 1. For this step you will need the following items as shown in the photograph above.

- #1 Fuselage (1)
- #2 Wing Mounting Dowels (2)
- #3 2.6mm x 8mm Wood Screws (4)
- #4 Molded Wing Dowel Covers (4)

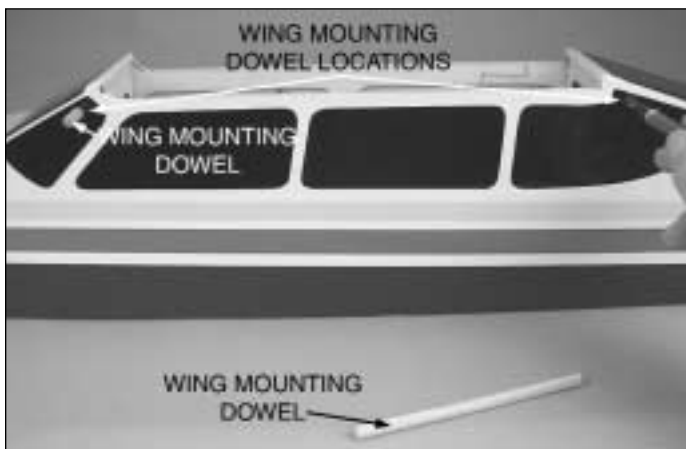

○ 2. Locate the four positions for the 7mm wing dowel holes by gently pressing the covering in the areas on the fuselage sides just below the wing saddles. These positions can be seen from the inside of the fuselage. Carefully cut the covering material from the holes using a sharp hobby knife.



○ 3. Insert both wing mounting dowels so they protrude an equal amount on both sides of the fuselage. Mix 1/4 oz. [7ml] of 30-minute epoxy. Apply glue around the dowels next to the fuselage and slide them in and out of the fuselage to help distribute the epoxy into the fuselage. Using a paper towel, spread the excess epoxy around the ends of the dowels. This will fuelproof and add strength to the wood. From the inside of the fuselage, apply more epoxy around the dowels where they meet the sides of the fuselage. These wing dowels will be used as the anchors for the **rubber bands** to hold the wing in position. Wipe off all excess epoxy using a paper towel and rubbing/denatured alcohol.

After the epoxy has cured, add the **molded wing dowel covers** and attach them with four **2.6mm x 8mm wood screws** into the pre-drilled holes in the ends of the wing dowels as shown in the photograph above.

# INSTALL THE FUEL TANK

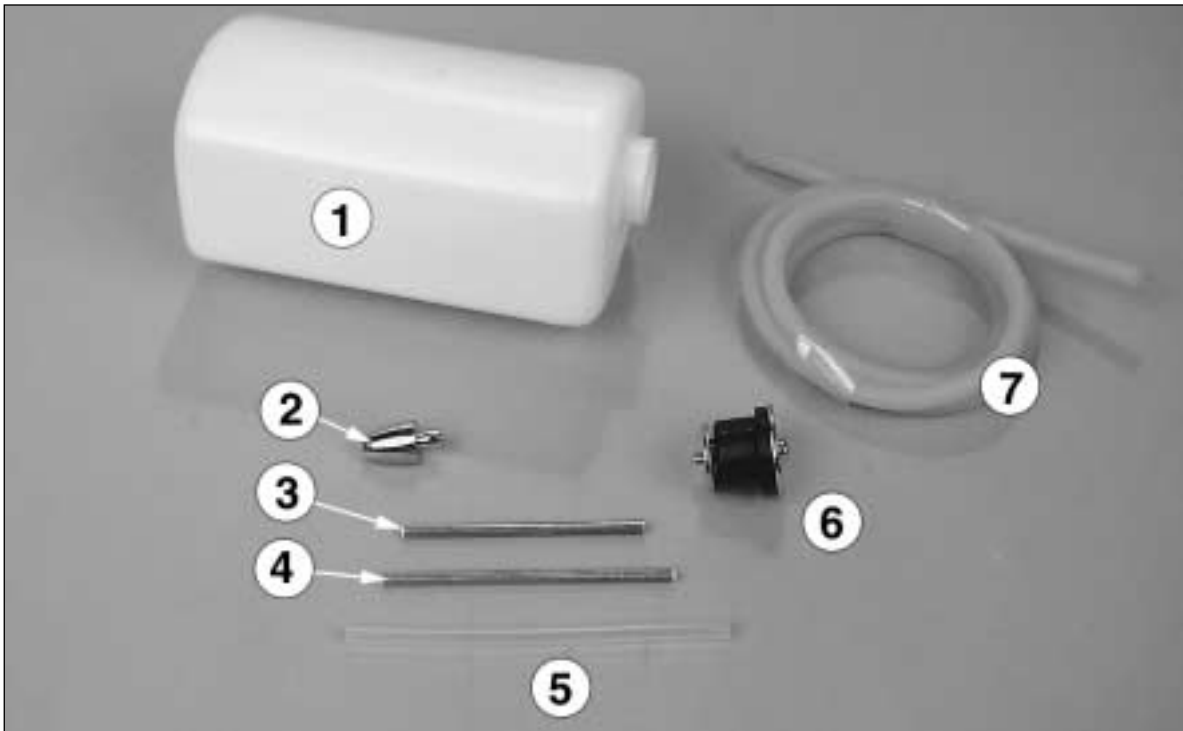

○ 1. To complete this step you will need the following items as shown in the photograph above.

- #1 Fuel Tank (1)
- #2 Clunk (1)
- #3 Fuel Pickup Tube (1)
- #4 Vent Tube (1)
- #5 Fuel Line for Pickup (1)
- #6 Stopper with Hardware (1)
- #7 Fuel Line (1)

**Note:** The fuel tank parts shown in the photo are placed inside the tank at the factory.



○ 2. Assemble the **stopper, tubes, and clunk** as shown in the photograph. Bend the vent tube so it is just below the top of the tank and then insert this assembly into in the tank. Tighten the screw to expand the stopper, thus sealing the tank. Be certain the clunk at the end of the fuel line inside the tank does not contact the rear of the tank. Otherwise, the line may become stuck above the fuel level and discontinue fuel flow.

Remember (or use a felt-tip pen to mark) which tube is the fuel pick-up tube and which tube is the vent (that will be connected to the pressure fitting on the muffler). Place the fuel lines on the vent and fuel pick-up tubes at this time.

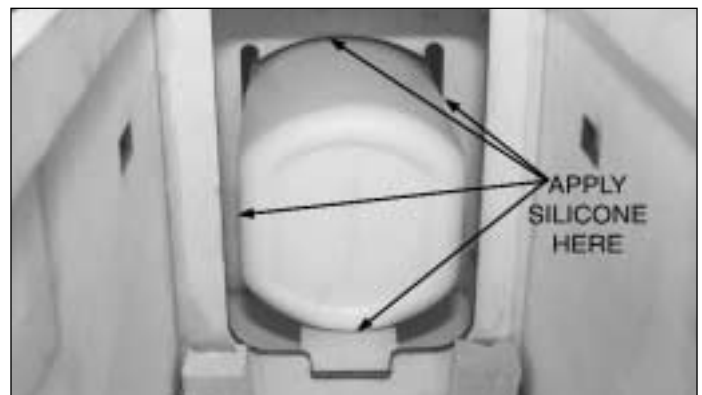
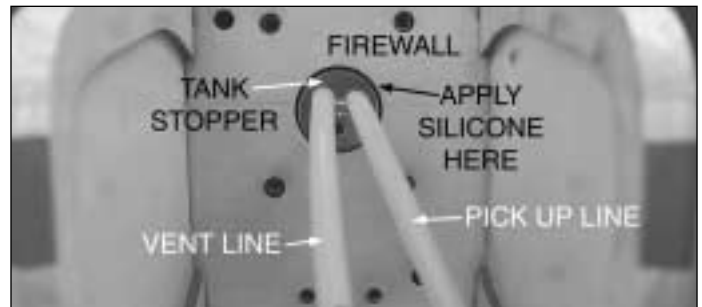

○ 3. Install the tank in the fuselage with the neck of the tank inserted into the hole in the firewall. Secure the tank into place with RTV silicone or Zap-A-Dap-A-Goo (PAAR3200) around the stopper and then slip the tank into place. Also put a bead of silicone around the stopper on the front of the firewall.

# MOUNT THE ENGINE

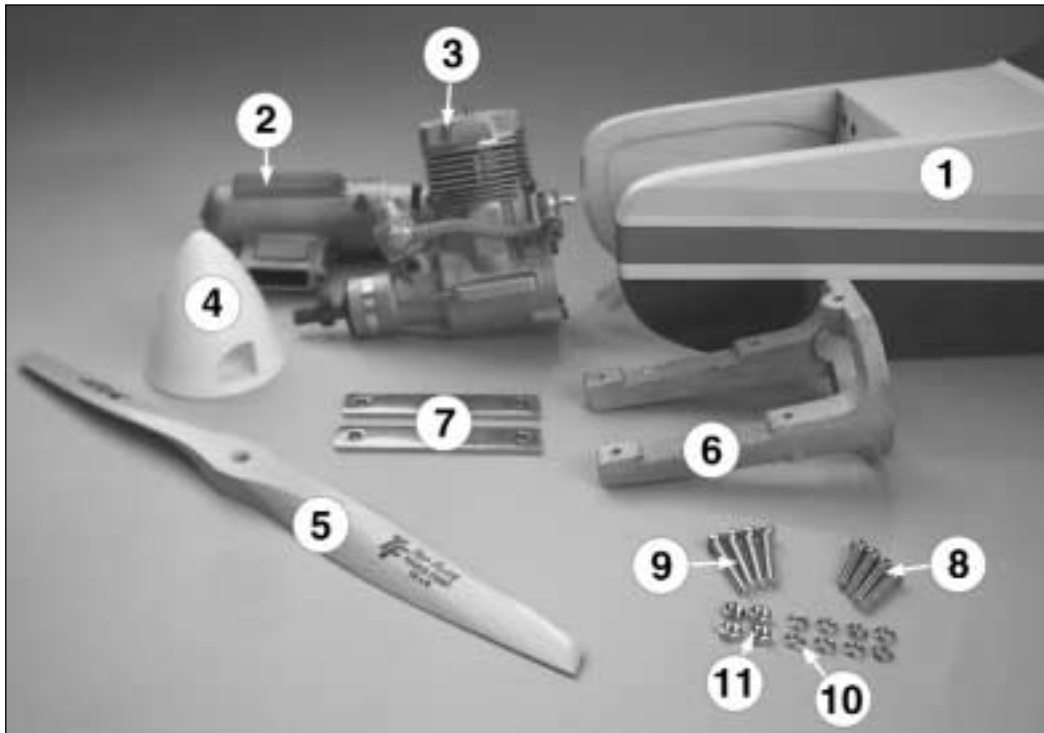

**NOTE:** The engine in your airplane is mounted slightly different from that of most R/C aircraft. This is done to allow the use of many different types of engines. It also allows a "no-drill" approach to ease the engine installation. Read through the procedure and understand all the steps before actually performing them.

○ 1. To complete this step you will need the following items as shown in the photograph above.

- #1 Fuselage (1)
- #2 Muffler for Engine (1) (not supplied)
- #3 Engine (1) (not supplied)
- #4 Spinner (1)
- #5 Propeller (1) (not supplied)
- #6 Engine Mount, .61 size (1)
- #7 Engine Mounting Straps (2)
- #8 4mm x 20mm Machine Screws (4)
- #9 4mm x 25mm Machine Screws (4)
- #10 4mm Lock Washers (8)
- #11 4mm Nuts (4)



○ 2. Secure the **engine mount** to the firewall with four **4mm x 20mm machine screws** and **4mm lock washers**. Use Threadlocker on the machine screws to keep them from vibrating loose. Blind nuts are pre-installed behind the firewall.

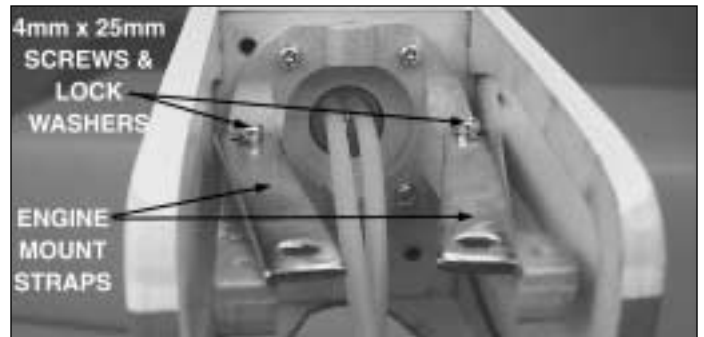

○ 3. The engine's mounting lugs are "sandwiched" between the engine mount and the **engine mount straps**. Begin by placing four 4mm lock washers onto each of the four **4mm x 25mm machine screws**.

Pass two of the screws through the two engine mount straps and place the screws through the back holes of the engine mount as shown in the photograph. Place two **4mm nuts** into the recesses on the bottom of the engine mount. Start the screws, but do not tighten them at this time.

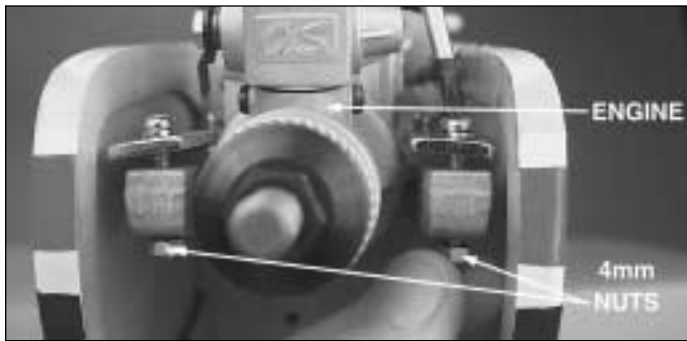

○ 4. With the engine in place, install the remaining two 4mm x 25mm machine screws, 4mm lock washers, and 4mm nuts in place at the front of the engine mount as shown in the photograph. Do not tighten the screws at this time to allow for the positioning of the engine.

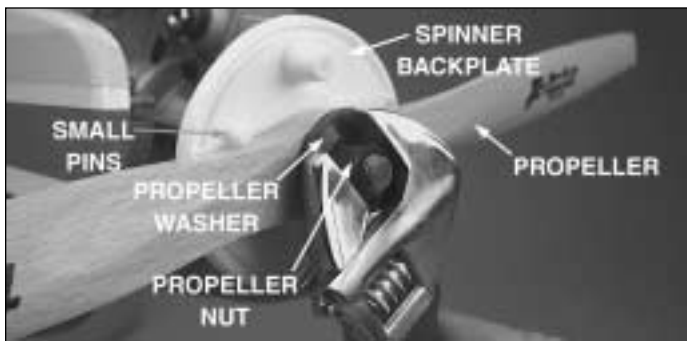

○ 5. Install the **spinner backplate**, propeller, propeller washer and the propeller nut onto the engine. Turn the propeller clockwise until it is against the smallest pins on the backplate. Keep the propeller horizontal when the engine is against its compression (the point at which you feel resistance when you turn the crankshaft counterclockwise). Use an adjustable wrench to securely tighten the propeller nut.



○ 6. Measure the distance from the spinner backplate to the firewall. It should be 5-1/2" [140mm] on **both sides** of the spinner backplate. Adjust the engine if needed and tighten the screws evenly, using Threadlocker on the screws and the nuts to secure the engine to the mount. Following the engine manufacturer's instructions, install the muffler to the engine.

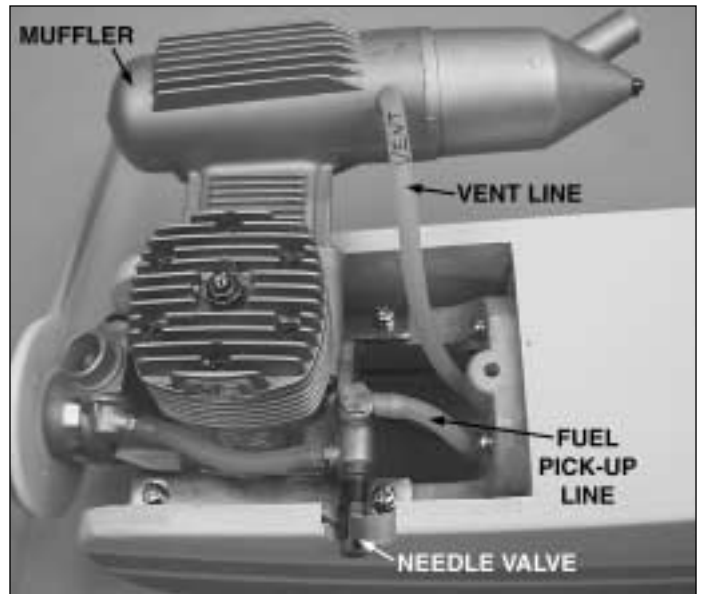

○ 7. Attach the fuel lines to the engine. The line you marked "Vent" should be attached to the muffler. The other line will be attached to the needle valve. Make sure there are no sharp bends in the lines. If so, carefully shorten the lines to allow for a smooth flowing bend to the appropriate fitting of the engine.



○ 8. Attach the **spinner cone** with the screws provided. Be careful not to overtighten these screws. They are threaded into plastic that can strip out if they are overtightened.

# MOUNT THE LANDING GEAR

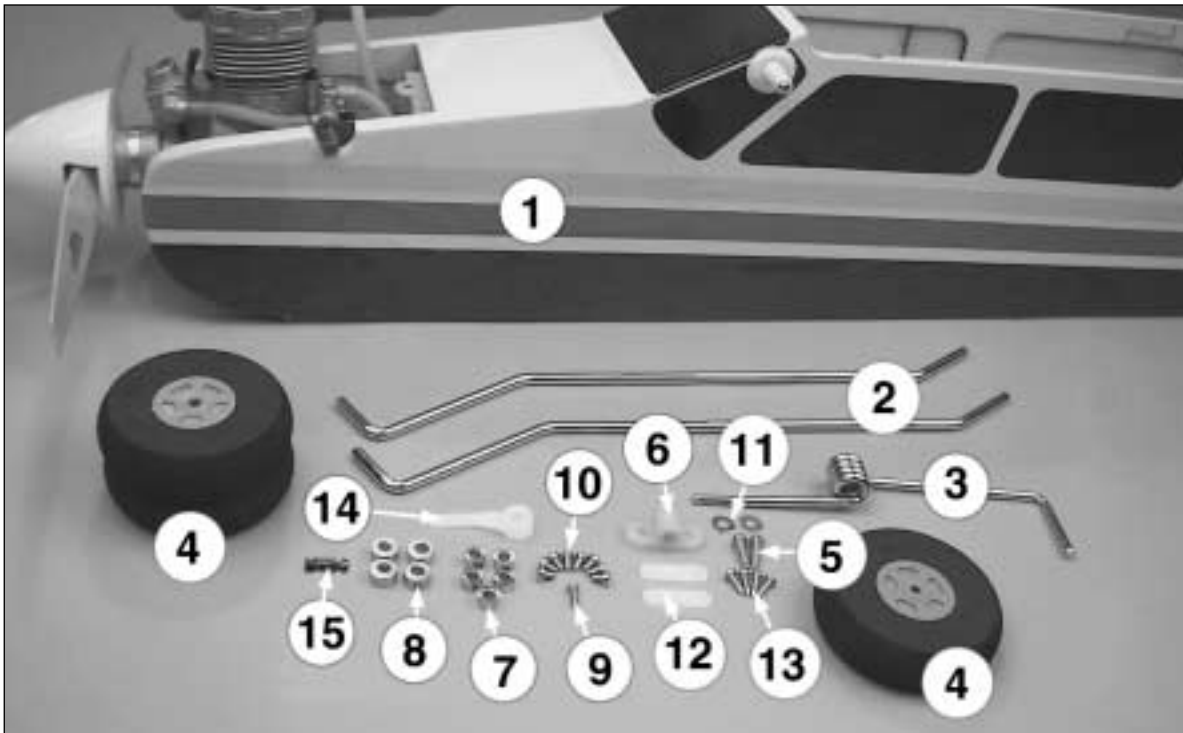

○ 1. The photo above shows the items you will need to complete this step. These parts are:

- #1 Fuselage (1)
- #2 Main Landing Gear (2)
- #3 Nose Gear (1)
- #4 Wheels (3), (2 with 5mm axle holes, 1 with 4mm axle holes)
- #5 4mm x 12mm Phillips Head Screws (2)
- #6 Nose Gear Bearing Block (1)
- #7 4mm Wheel Collars (5)
- #8 5mm Wheel Collars (4)
- #9 3mm x 8mm Phillips Head Set Screw (1) For Nose Gear Steering Arm Only
- #10 3mm x 5mm Phillips Head Set Screw (8)
- #11 4mm Flat Washers (2)
- #12 Landing Gear Straps (2)
- #13 3mm X 10mm Phillips Head Wood Screws
- #14 Nylon Steering Arm (1)
- #15 Screw-Lock Pushrod Connector Assembly (1)

**Important Note:** The main landing gear has a diameter of 5mm and the nose gear's diameter is 4mm. Look carefully at the wheels and wheel collars used during the following steps and you will notice that one wheel has a 4mm hole for the axle. This wheel is the nose wheel only. The same is true with the wheel collars. Use the 4mm collars to assemble the nose gear.



○ 2. Test fit the two main **landing gear wires** into the pre-drilled holes inside the channel located in the bottom of the fuselage. If they will not go in easily, drill out the two holes using a 5/32" [4mm] drill bit. Next, use the drill bit or hobby knife to bevel the inside corners of the holes so that the bend in the wire will seat fully into the holes and the wire will be flush with the bottom of the fuselage. Place the landing gear wires into the channel. Look carefully and you will find four pre-drilled holes under the covering. They can be seen in the photograph.

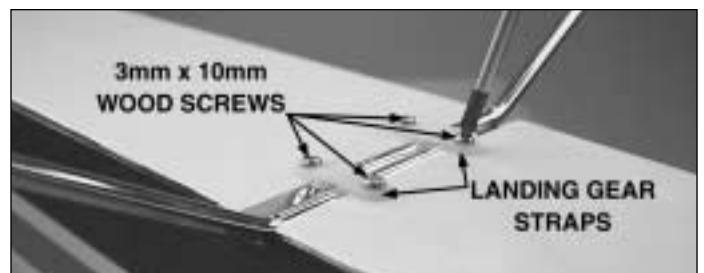

○ 3. At the locations of the pre-drilled holes attach the **nylon landing gear straps** to the fuselage using the four

**3mm x 10mm Phillips head wood screws** and the nylon landing gear straps as shown in the photograph.

and then gently tighten the nut. It is important not to overtighten this nut; this would not allow the screw-lock pushrod connector to rotate on the steering arm while in operation. Adjust the tightness of the nut and test the connector's ability to rotate but still be somewhat tight. When you are satisfied with this adjustment place a small amount of Threadlocker on the top of the nut and allow it to wick down into the threads.

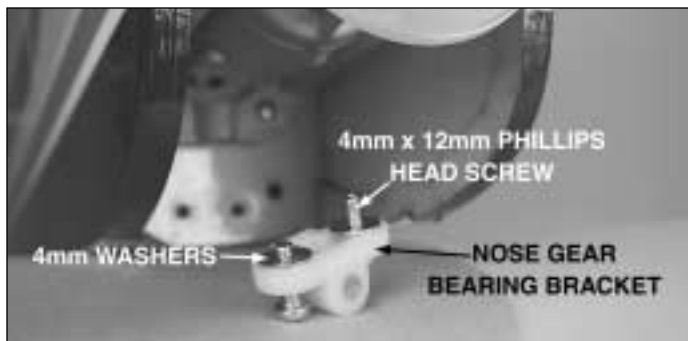

○ 4. Install the nose gear by attaching the **nose gear bearing bracket** to the firewall with two **4mm x 12mm Phillips head screws** and the two **4mm washers** which must go **behind** the bracket so they act as spacers as shown in the photograph above. Apply Threadlocker to these screws before installing them.



○ 7. Place another wheel collar with a **3mm x 5mm Phillips head set screw** onto the nose gear wire. Then insert the nose gear wire into the nose gear bearing bracket. As you slide it through the bearing bracket, hold the assembled steering arm in place and slide the nose gear through the steering arm and into the hole in the bottom of the engine mount. Note that the existing flat spot on the nose gear wire is facing forward. When you have the nose gear installed, tighten the two Phillips head set screws in the wheel collars to complete the installation.



○ 5. The steering arm should be cut off as shown in the above photograph. Place one of the wheel collars into the steering arm base, making sure the threaded hole for the set screw is aligned with the hole in the steering arm base as shown in the photograph above. The **3mm x 8mm Phillips head set screw** is then placed into the wheel collar through the hole in the base of the steering arm.

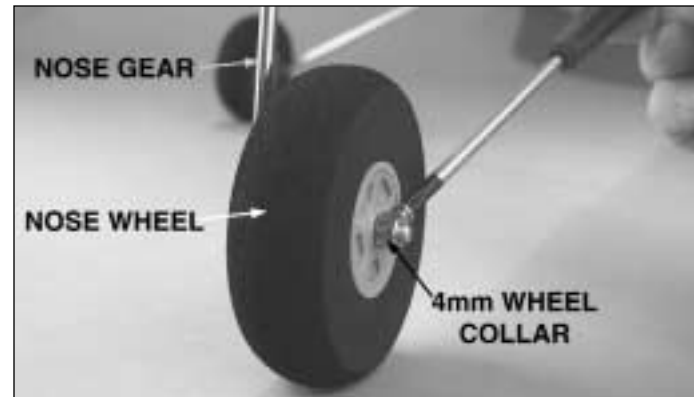

○ 8. Place a 5mm wheel collar and a wheel on each of the two main landing gear **axles**. Add the second 5mm wheel collar on the outside of the wheel to each axle. Center the wheel on the axles. Mark the location of the outer wheel collar on the axles with a felt-tipped pen. Remove the wheel collars and wheels; then, file or grind a 1/4" [6mm] flat spot on the axles at the locations you marked. This is done to prevent the wheel collar from turning or becoming loose during flight. Secure the 2 wheels on the axles using the 3mm x 5mm Phillips head set screws in the wheel collars, using Threadlocker on the set screws to hold them securely in place.



○ 6. Place the **screw-lock pushrod connector** onto the **steering arm** exactly as shown in the above photograph. **Important Note:** The screw-lock pushrod connector is assembled in the bag. In order to place it onto the steering arm you will need to remove the wheel-type nut and the washer on the end of the unit. Insert the threaded stem of the unit into the hole on the steering arm in the manner shown in the photograph. Place the washer on the threaded stem followed by the wheel-type nut. Apply Threadlocker to the threaded stem

Repeat this process for the nose gear using 4mm wheel collars and the wheel with the 4mm hole for the axle. Double check all the wheels to make sure they still spin freely. If not, move the inner wheel collar away from the wheel slightly and retighten the screw.

# FINAL ASSEMBLY

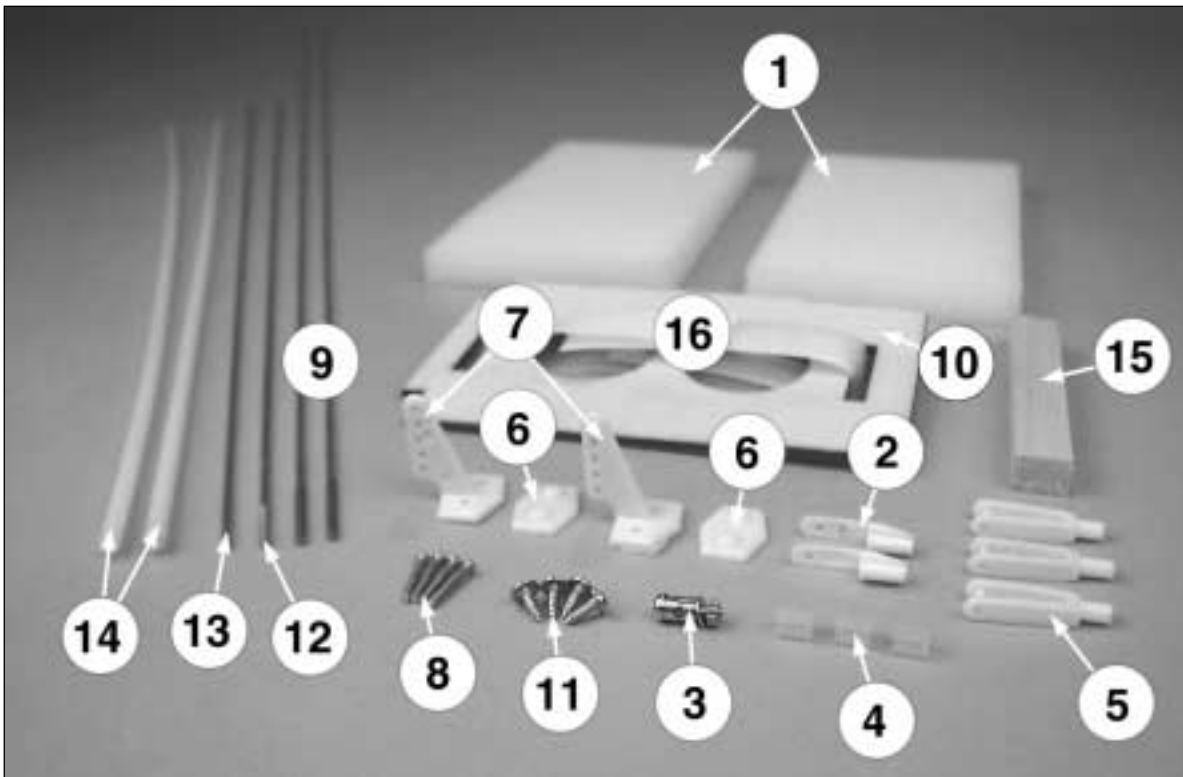

## HOOK UP THE CONTROLS

○ 1. The items shown in the above photograph will be needed from the airplane kit to complete this step. These items are:

#1 Protective Foam (2)

#2 Faslinks (2)

#3 Screw-Lock Pushrod Connector (1)

#4 Silicone Clevis Retainers (3)

#5 Clevises (3)

#6 Control Horn Backplates (2)

#7 Control Horns (2)

#8 2mm x 14mm Phillips Head Screws (4)

#9 680mm Threaded Elevator/Rudder Pushrods (2)

#10 Battery/Receiver Tray (1)

#11 2.6mm x 8mm Screws (4)

#12 Threaded One End Throttle Pushrod (1)

#13 Un-threaded Steering Pushrod (1)

#14 Plastic Steering/Throttle Pushrod Guide Tubes (2)

#15 10mm x 13mm x 87mm Balsa Pushrod Support (1)

#16 Hook and Loop Material (2)

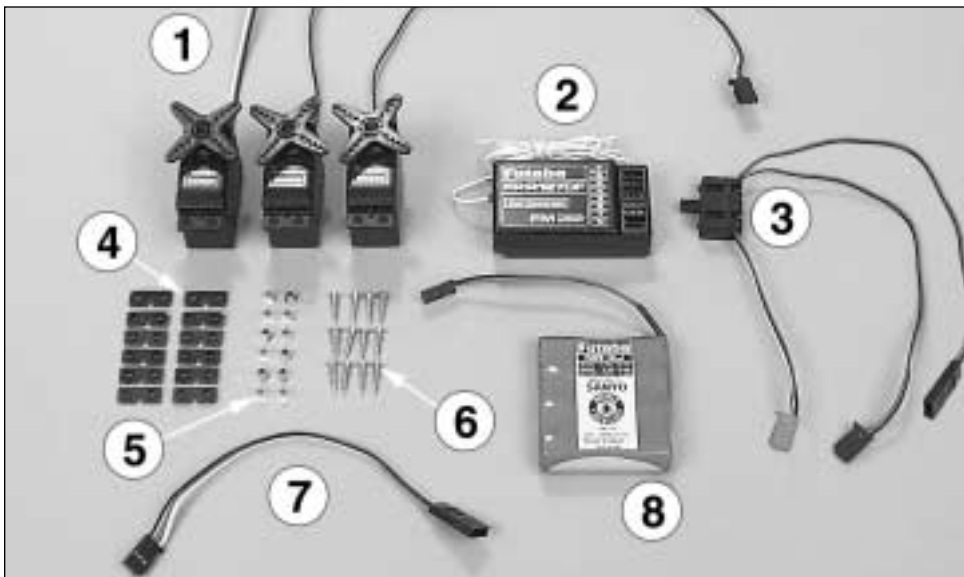

○ 2. The items shown will be needed from the radio system to complete this step.

#1 Servos (3)

#2 Receiver (1)

#3 Switch Harness (1)

#4 Rubber Grommets (12)

#5 Brass Eyelets (12)

#6 Servo Mounting Screws (12)

#7 Aileron Extension (1)

#8 Battery Pack (1)



○ 3. There is a 5mm hole in the **firewall** for the **pushrod guide tube** that will align with the throttle arm on most two-stroke engines. Use medium sandpaper to roughen both plastic pushrod guide tubes. Insert one pushrod guide tube through the hole in the firewall for the throttle, and the other for the steering pushrod guide tube.



○ 4. Thread a **nylon clevis** 25 full turns onto the threaded pushrod wire. Slip a **silicone retainer** over the clevis. Insert the pushrod with the clevis all the way into the throttle guide tube and connect the clevis to the throttle arm on the engine as shown in the photograph above.

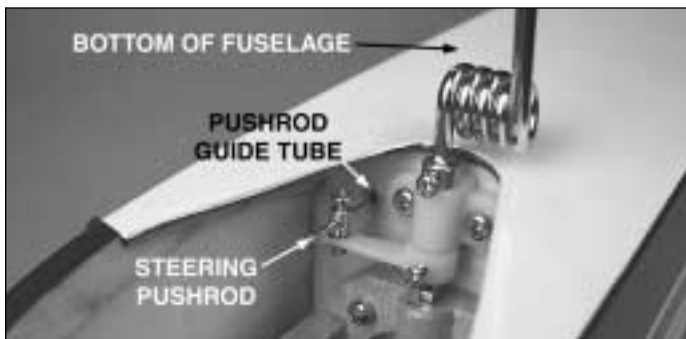

○ 5. **Note:** The above photograph is taken from the bottom of the fuselage. Run the un-threaded steering pushrod through the screw-lock pushrod connector and continue pushing it all the way into the steering rod guide tube. Position the pushrod guide tubes to extend approximately 1/8" [3mm] past the firewall and glue them into place using 6-minute epoxy.

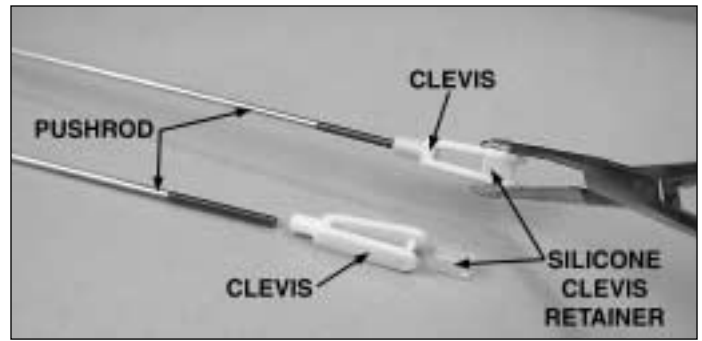

○ 6. Screw two nylon clevises 25 full turns onto the two threaded wire pushrods. Slip silicone retainers over the clevises. Slit the covering material where the guide tubes exit the fuselage with a hobby knife. The location of the rudder tube exit is on top of the fuse next to the fin and the elevator tube exit is located on the same side of fuse under the stab. After you have made your cuts, slide the assembled pushrods through the guide tubes.

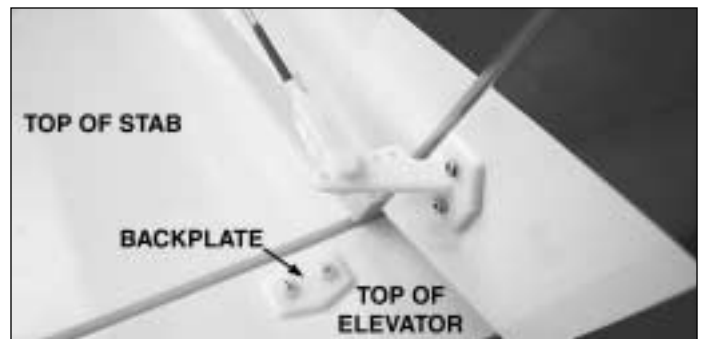
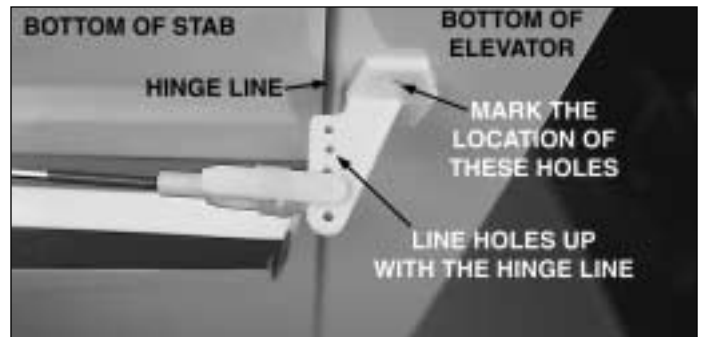

○ 7. Connect the clevises to the **control horns**, placing them in the second hole from the end of the horn as shown. Position the control horns on the elevator and rudder as shown in the photograph. The row of holes in the horns should be over the hinge line. If necessary small bends may be made in the pushrods to position them with the control surfaces. Mark the locations of the holes in the base of the

control horns on the elevator and rudder. At these locations drill 5/64" [2mm] holes through the elevator and rudder for mounting the control horns with 2mm x 14mm Phillips head screws. Mount the control horns using the nylon back plates on the other side of the control surfaces.

## INSTALL THE RADIO GEAR

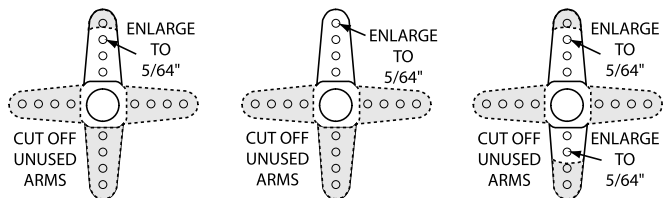

**Elevator Arm    Throttle Arm    Rudder/Steering Arm**

○ 1. You must modify 3 servo arms to be used in this section. Starting with the 4 armed servo arms supplied with your radio system, modify them exactly as shown in the above illustration. Enlarge the holes in the locations shown with a **Hobbico Servo Horn Drill** (or a #48 or 5/64" [2mm] drill bit).

**Note:** You may wish to trim the excess material from the arms as shown in the illustration and the following photographs.

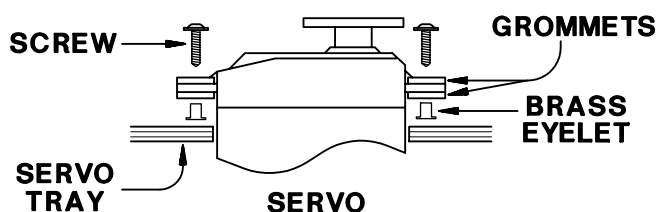

○ 2. Place the grommets and brass eyelets on the three servos using the diagram above and your radio system instructions as a guide. Place the servos in the **servo tray** in the orientation shown in the following photograph.

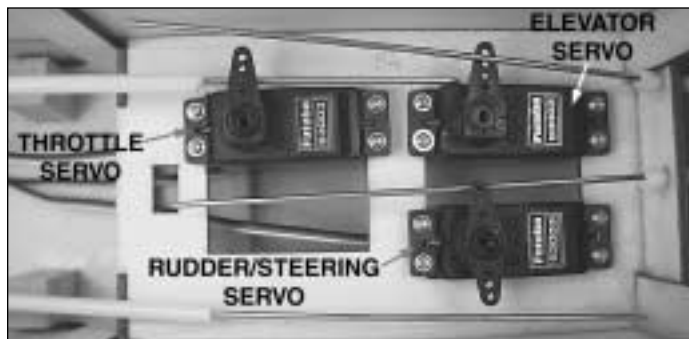

○ 3. With your servo arms aligned at 90-degrees to the servos, position the servos so the holes in the servo arms, the holes you enlarged, cross the elevator and rudder pushrods. Carefully mark on the servo tray, the four locations of each servo for the **servo mounting screws**. At these locations drill 1/16" [1.6mm] holes through the servo tray. Install the servo mounting screws and then remove

them, creating threads in the wood at all the locations. Add a drop of thin CA to each hole and allow it to harden (it is best to take the servos out of the tray while doing this to avoid gluing the servos to the tray). Reposition the servos and mount them to the tray with the screws. **Note:** Run your servo lead wires forward as shown in the photos.

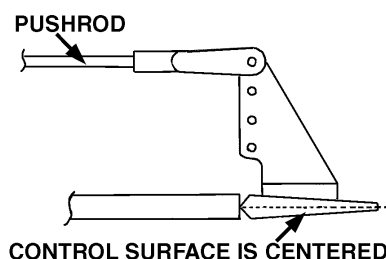

○ 4. With the servos mounted into place, carefully center the rudder with the fin and the elevator with the stab. While the control surfaces are centered, use a felt-tip pin to place a mark on the pushrod wires at the location of the hole in the elevator and rudder servo arms as shown in the above photograph.

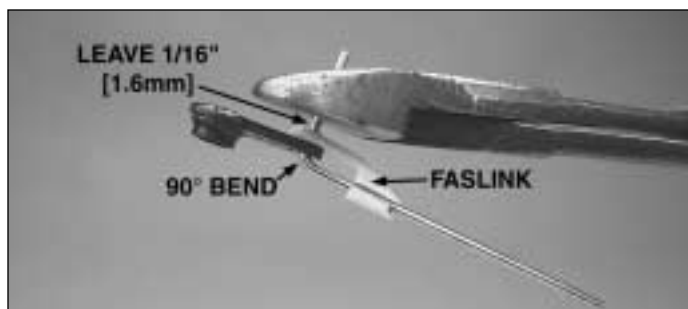

○ 5. Use pliers to make a 90° bend at the marks on the two pushrods. Disconnecting the clevises from the elevator and rudder control horns will make this easier to do. Remove the servo arms from the servos and run the pushrod through

the holes in the servo arms from the bottom of the arms. Place nylon Faslinks to each pushrod, and then cut the wires with 1/16" [1.5mm] protruding from the Faslinks. Reattach the clevises to the control horns and replace the servo arms on the servos.



○ 6. Use a hobby knife with a sharp blade and cut the steering pushrod guide tube at the location shown in the above photograph. Do not cut the steering pushrod at this time. Carefully align the nose wheel as straight as possible. Align the steering pushrod with the second hole (out from the center) in the rudder servo arm and place a mark on the steering pushrod as shown in the above photograph. As you did with the previous pushrods, make a 90° bend at the mark, install the servo arm and the Faslink, and cut off the excess steering pushrod.

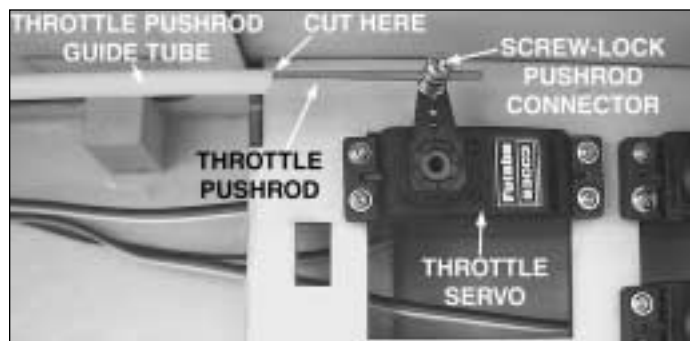

○ 7. Center the throttle servo arm on the throttle servo as shown in the above photograph. Remove the throttle servo arm and install the screw-lock pushrod connector in the last hole on the servo arm. Slip the throttle pushrod into the screw-lock pushrod connector and replace the servo arm onto the servo.

Before tightening the screw-lock pushrod connector, look inside the carburetor on the engine and move the throttle pushrod until the barrel of the carburetor is 1/2 open. With

the throttle servo arm still centered on the servo, tighten the screw on top of the screw-lock pushrod connector. Using the above photograph as a reference, cut off the excess throttle pushrod but leave a minimum of 1/2" (13mm) of excess rod for adjustments later.

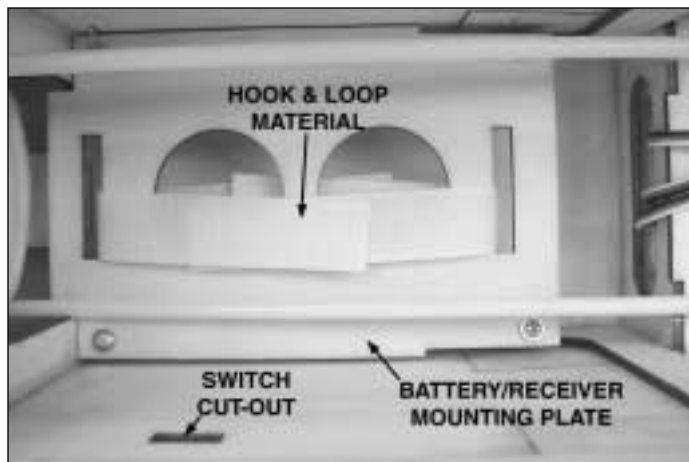

○ 8. Install the **battery/receiver mounting plate** into the fuselage using four 3mm x 10mm Phillips head screws as shown in the above photograph. **Note:** You may place the supplied **hook and loop material** into the battery/receiver mounting plate prior to mounting the plate into the fuselage. It is a bit more difficult if you wait to do this when you mount the receiver and battery. Refer to step #10 for location.

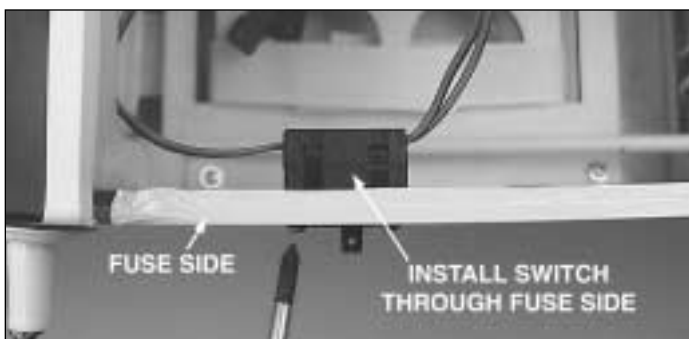

○ 9. Locate the cutout for the **on/off switch** on the left side of the fuselage, away from your engine exhaust, and cut the covering from this cutout. Remove the cover plate from the radio system on/off switch and use it as a pattern to drill the two holes on either side of the cutout. This will allow you to mount the on/off switch by placing the two screws back into the cover plate and placing them through the fuselage side. Hold the on/off switch in place and re-insert and tighten the two screws in the on/off switch.

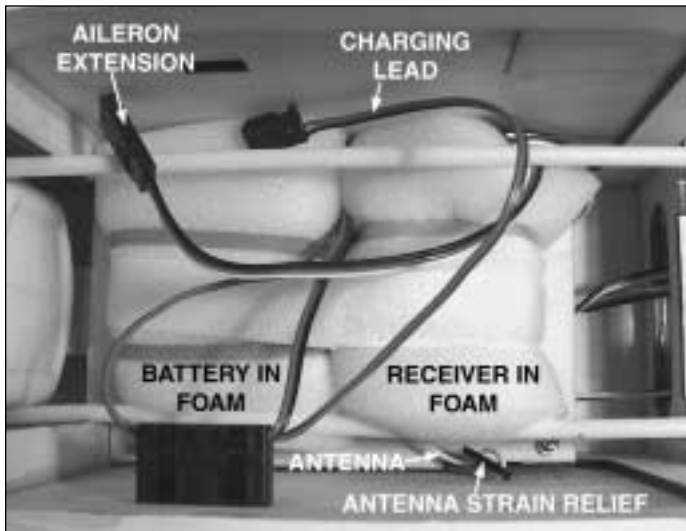

○ 10. Connect the aileron extension, servo leads, battery and switch wires to the receiver as directed by your radio system instructions. Wrap both the battery pack and receiver in the supplied **protective foam rubber** to protect them from vibration. Secure both the battery pack and receiver in the model by placing the supplied hook and loop material through the slots in the battery/receiver mounting plate and then around the battery and receiver.

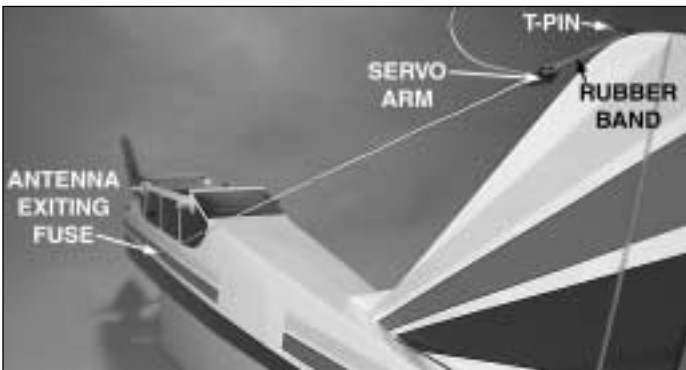
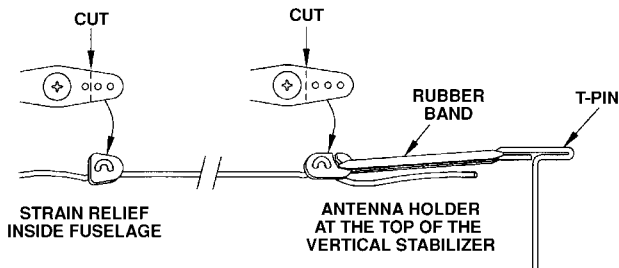

○ 11. Make a strain relief from one of the cut-off servo arms and install it on the antenna. Route the receiver antenna out of the fuselage as close to the receiver as you can by drilling a 5/64" (2mm) hole in the side of the fuselage and running the antenna through the side of the fuselage. Connect the antenna to a hook made from another leftover servo arm that's connected to a rubber band and a T-pin inserted into the top of the fin.

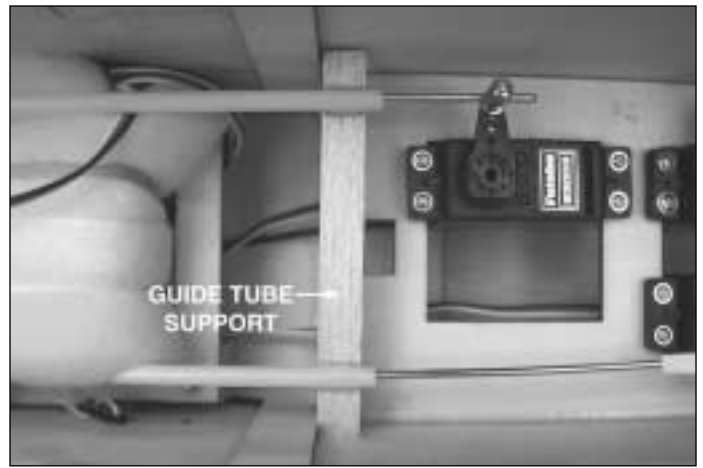

○ 12. Make a **guide tube support** by using the supplied 10mm x 13mm x 87mm balsa material. Place it into the fuse as shown in the photograph above and mark the locations of the throttle and steering guide tubes. Cut, sand, or file a "V" or notch at these locations. Use sandpaper to roughen the outer surface of the tubes where they meet the guide tube support.

Reposition the guide tube support, making sure the tubes rest in the slots and do not bind or put pressure on the pushrods. When satisfied with the fit, glue the support into place and glue the guide tubes to the support using 6-minute epoxy. Be careful not to get glue in the opening of the guide tube or on the pushrod.

## APPLY THE DECALS

○ 1. Use scissors or a sharp hobby knife to cut the decals from the sheet.

○ 2. Be certain the model is clean and free from oily fingerprints and dust. Prepare a dishpan or small bucket with a mixture of liquid dish soap and warm water—about one teaspoon of soap per gallon of water. Submerge the decal in the soap and water and peel off the paper backing. **Note:** Even though the decals have a "sticky-back" and are not the water transfer type, submersing them in soap & water allows accurate positioning and reduces air bubbles underneath.

○ 3. Position decal on the model where desired. Holding the decal down, use a paper towel to wipe most of the water away.

○ 4. Use a piece of soft balsa or something similar to squeegee remaining water from under the decal. Apply the rest of the decals the same way.

## GET THE MODEL READY TO FLY

### Check the Control Directions

○ 1. **Note:** Also refer to your instructions provided with your radio system for the following steps. Turn on the transmitter and receiver and center the trims on the transmitter. If necessary, remove the servo arms from the servos and reposition them so they are centered. Reinstall the screws that hold on the servo arms.

○ 2. With the transmitter and receiver still on, check all the control surfaces to see if they are centered. Use a straightedge to help get them set correctly. If necessary, adjust the clevises on the pushrods to center the control surfaces.

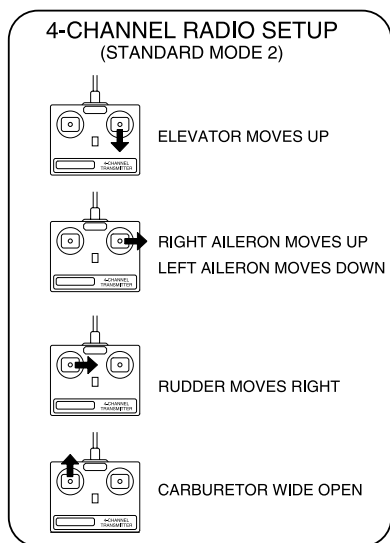

○ 3. Make certain that the control surfaces and the carburetor respond in the correct direction as shown in the diagram above. If any of the controls respond in the wrong direction, use the servo reversing switches in the transmitter to reverse the servos connected to those controls. Be certain the control surfaces have remained centered. Re-adjust if necessary.

For added safety and convenience, the throttle should be set up so that the engine can be stopped using the throttle trim. To do this remove the clevis from the carburetor arm and move the throttle pushrod so that the carburetor is completely closed with the throttle stick and trim lever on the transmitter fully back/down. Next, adjust the clevis so that when the clevis is connected the carburetor barrel is in the fully closed position. Then test the trim lever by advancing it to full. This will be a fast idle position with the carburetor barrel open slightly (about 1/32" or .8mm).

Now move the throttle stick forward to full. Make sure that the carburetor barrel opens all the way. If it doesn't open far enough or opens too far (bending the rod) move the pushrod and screw-lock pushrod connector in or out on the servo arm and/or the clevis on the carburetor arm to gain or reduce movement. The throw will be correct when the carburetor barrel will stop fully open at the same time the throttle stick reaches full. With the throttle set up properly, you should be able to run the engine with the trim lever set midway to the full position (adjusted for a smooth but slow idle). Then when it is time to stop the engine, simply pull back the trim to close the carburetor and the engine will stop running.

### Set the Control Throws

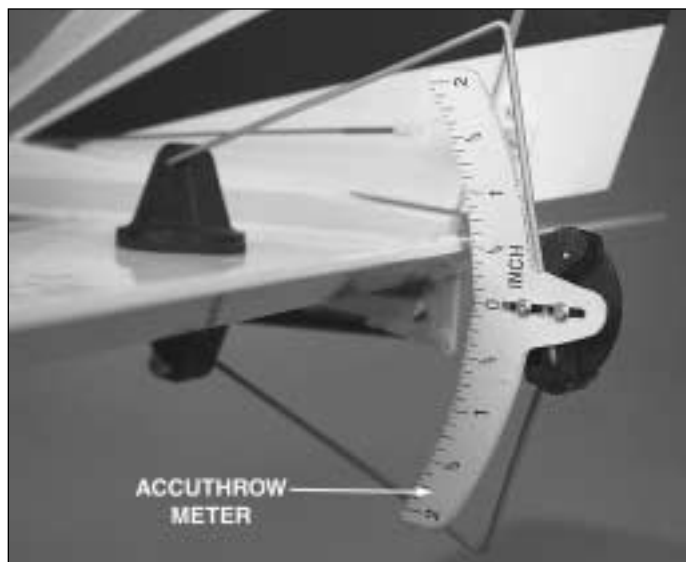

Use a **Great Planes AccuThrow™** (or a ruler) to accurately measure and set the control throw of each control surface as indicated in the chart that follows. If your radio does not have dual rates, we recommend setting the throws at the **low** rate setting.

**Note:** The throws are measured at the **widest part** of the elevator, rudder and ailerons.

#### These are the recommended control surface throws:

	High Rate	Low Rate
<b>ELEVATOR:</b>	5/8" [16mm] up 5/8" [16mm] down	1/2" [13mm] up 1/2" [13mm] down
<b>RUDDER:</b>	3/4" [19mm] left 3/4" [19mm] right	5/8" [16mm] left 5/8" [16mm] right
<b>AILERONS:</b>	5/8" [16mm] up 5/8" [16mm] down	1/2" [13mm] up 1/2" [13mm] down

**IMPORTANT:** The Tower Trainer 60 MKII ARF has been **extensively** flown and tested to arrive at the throws at which it flies best. Flying your model at these throws will provide you with the greatest chance for successful first flights. If, after you have become accustomed to the way the Tower Trainer 60 MKII ARF flies, you would like to change the throws to suit your taste, that is fine. However, too much control throw could make the model difficult to control, so remember, "more is not always better."

## Balance the Model (C.G.)

More than any other factor, the **C.G.** (center of gravity or, balance point) can have the **greatest** effect on how a model flies, and may determine whether or not your first flight will be successful. If you value this model and wish to enjoy it for many flights, **DO NOT OVERLOOK THIS IMPORTANT PROCEDURE.** A model that is not properly balanced will be unstable and possibly unflyable.

At this stage the model should be in ready-to-fly condition with all of the systems in place including the engine, landing gear, and the radio system.

- 1. Use a felt-tip pen or 1/8"-wide tape to accurately mark the C.G. on the bottom of the wing on both sides of the fuselage. The C.G. is located 3-3/4" [95mm] back from the leading edge of the wing.

This is where your model should balance for your first flights. Later, you may wish to experiment by shifting the C.G. up to 1/4" [6mm] forward or 1/4" [6mm] back to change the flying characteristics. Moving the C.G. forward may improve the smoothness and stability, but it may then require more speed for takeoff and make it more difficult to slow for landing. Moving the C.G. aft makes the model more maneuverable, but could also cause it to become too difficult for you to control. In any case, start at the location we recommend and do not at any time balance your model outside the recommended range.

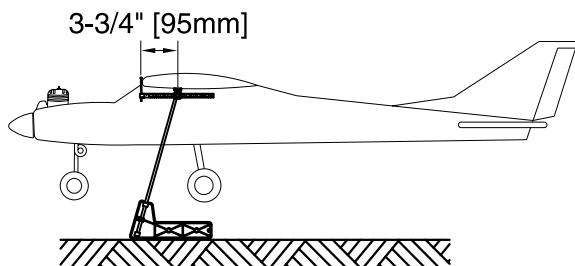

- 2. With the wing attached to the fuselage, all parts of the model installed (ready to fly) and an empty fuel tank, place the

model on a **Great Planes CG Machine**, or lift it at the balance point you marked.

- 3. If the tail drops, the model is "tail heavy" and the battery pack and/or receiver must be shifted forward or weight must be added to the nose to balance. If the nose drops, the model is "nose heavy" and the battery pack and/or receiver must be shifted to the rear or weight must be added to the tail to balance. If possible, relocate the battery pack and receiver to minimize or eliminate any additional ballast required. If additional weight is required, nose weight may be easily added by using a "spinner weight" (GPMQ4645 for the 1 oz. weight, or GPMQ4646 for the 2 oz. weight). If spinner weight is not practical or is not enough, use Great Planes (GPMQ4485) "stick-on" lead. A good place to add stick-on nose weight is to the firewall. Begin by placing incrementally increasing amounts of weight on the fuselage over the firewall until the model balances. Once you have determined the amount of weight required, it can be permanently attached. If required, tail weight may be added by cutting open the bottom of the fuselage and gluing it permanently inside.

**Note:** Do not rely upon the adhesive on the back of the lead weight to permanently hold it in place. Over time, fuel and exhaust residue may soften the adhesive and cause the weight to fall off. Use #2 sheet metal screws, RTV silicone or epoxy to permanently hold the weight in place.

- 4. **IMPORTANT:** If you found it necessary to add any weight, recheck the C.G. after the weight has been installed. Also, if you found it necessary to move any radio components, make sure it is securely re-installed inside the fuselage.

## Balance the Model Laterally

- 1. With the wing level, have an assistant help you lift the model by the engine propeller shaft and the bottom of the fuselage under the TE of the fin. Do this several times.

- 2. If one wing always drops when you lift the model, it means that side is heavy. Balance the airplane by adding the necessary amount of stick-on weight to the other wing tip. **An airplane that has been laterally balanced will track better in loops and other maneuvers.**

## PREFLIGHT

### Identify Your Model

No matter if you fly at an AMA sanctioned R/C club site or if you fly somewhere on your own, you should always have your name, address, telephone number and AMA number on or inside your model. It is **required** at all AMA R/C club flying sites and AMA sanctioned flying events. Fill out the identification tag at the center section of this manual and place it on or inside your model.

### Charge the Batteries

Follow the battery charging instructions that came with your radio control system to charge the batteries. You should always

charge your transmitter and receiver batteries the night before you go flying, and at other times as recommended by the radio manufacturer.

**Note:** Checking the condition of your receiver battery pack is **highly recommended**. All battery packs, whether it's a trusty pack you've just taken out of another model, or a new battery pack you just purchased, should be cycled, noting the discharge capacity. Oftentimes, a weak battery pack can be identified (and a valuable model saved!) by comparing its actual capacity to its rated capacity. Refer to the instructions and recommendations that come with your cyler. If you don't own a battery cyler, perhaps you can have a friend cycle your pack and note the capacity for you.

### Balance the Propellers

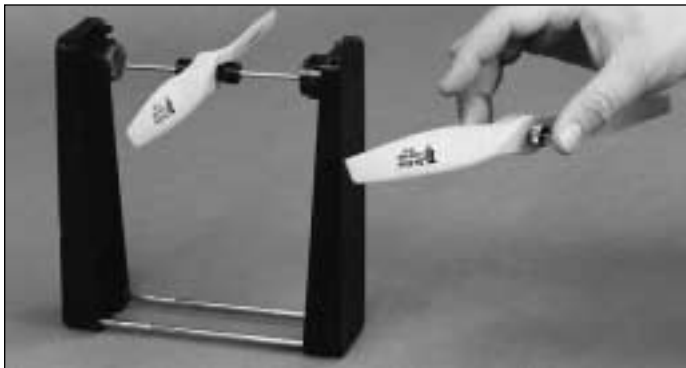

Carefully balance your propeller and spare propellers before you fly. An unbalanced prop can be the single most significant cause of vibration that can damage your model. Not only will engine mounting screws and bolts loosen, possibly with disastrous effect, but vibration may also damage your radio receiver and battery. Vibration can also cause your fuel to foam, which will, in turn, cause your engine to run hot or quit.

We use a Top Flite Precision Magnetic Prop Balancer™ (TOPQ5700) in the workshop and keep a Great Planes Fingertip Prop Balancer (GPMQ5000) in our flight box.

### Ground Check

**If the engine is new, follow the engine manufacturer's instructions to break-in the engine.** After break-in, confirm that the engine idles reliably, transitions smoothly and rapidly to full power and maintains full power—indefinitely. After you run the engine on the model, inspect the model closely to make sure all screws remained tight, the hinges are secure, the prop is secure and all pushrods and connectors are secure.

### Range Check

Refer to your radio system's manual and ground check the operational range of your radio before the first flight of the day. With the transmitter antenna collapsed and the receiver and transmitter on, you should be able to walk at least 100 feet away from the model and still have control. Have an assistant stand by your model and, while you work the controls, tell you what the control surfaces are doing. Repeat this test with the engine

running at various speeds with an assistant holding the model, using hand signals to show you what is happening. If the control surfaces do not respond correctly, do not fly! Find and correct the problem first. Look for loose servo connections or broken wires, corroded wires on old servo connectors, poor solder joints in your battery pack or a defective cell, or a damaged receiver crystal from a previous crash.

## ENGINE SAFETY PRECAUTIONS

**Failure to follow these safety precautions may result in severe injury to yourself and others.**

Keep all engine fuel in a safe place, away from high heat, sparks or flames, as fuel is very flammable. Do not smoke near the engine or fuel; and remember that engine exhaust gives off a great deal of deadly carbon monoxide. Therefore, **do not run the engine in a closed room or garage.**

Get help from an experienced pilot when learning to operate engines.

Use safety glasses when starting or running engines.

Do not run the engine in an area of loose gravel or sand; the propeller may throw such material in your face or eyes.

Keep your face and body as well as all spectators away from the plane of rotation of the propeller as you start and run the engine.

Keep these items away from the prop: loose clothing, shirt sleeves, ties, scarves, long hair or loose objects such as pencils or screwdrivers that may fall out of shirt or jacket pockets into the prop.

Use a "chicken stick" or electric starter to start the engine. Do not use your fingers to flip the propeller. Make certain the glow plug clip or connector is secure so that it will not pop off or otherwise get into the running propeller.

Make all engine adjustments from behind the rotating propeller.

The engine gets hot! Do not touch it during or right after operation. Make sure fuel lines are in good condition so fuel will not leak onto a hot engine, causing a fire.

To stop a glow engine, cut off the fuel supply by closing off the fuel line or following the engine manufacturer's recommendations. Do not use hands, fingers or any other body part to try to stop the engine. Do not throw anything into the propeller of a running engine.

## AMA SAFETY CODE (excerpts)

Read and abide by the following Academy of Model Aeronautics Official Safety Code:

### GENERAL

1. I will not fly my model aircraft in sanctioned events, air shows, or model flying demonstrations until it has been proven to be airworthy by having been previously successfully flight-tested.

2. I will not fly my model aircraft higher than approximately 400 feet within 3 miles of an airport without notifying the airport operator. I will give right of way to, and avoid flying in the proximity of full-scale aircraft. Where necessary an observer shall be used to supervise flying to avoid having models fly in the proximity of full-scale aircraft.

3. Where established, I will abide by the safety rules for the flying site I use, and I will not willfully and deliberately fly my models in a careless, reckless and/or dangerous manner.

4. I will not fly my model unless it is identified with my name and address or AMA number, on or in the model.

5. I will not operate models with pyrotechnics (any device that explodes, burns, or propels a projectile of any kind).

### RADIO CONTROL

1. I will have completed a successful radio equipment ground check before the first flight of a new or repaired model.

2. I will not fly my model aircraft in the presence of spectators until I become a qualified flier, unless assisted by an experienced helper.

3. I will perform my initial turn after takeoff away from the pit or spectator areas, and I will not thereafter fly over pit or spectator areas, unless beyond my control.

4. I will operate my model using only radio control frequencies currently allowed by the Federal Communications Commission.

### CHECK LIST

During the last few moments of preparation your mind may be elsewhere anticipating the excitement of the first flight. Because of this, you may be more likely to overlook certain checks and procedures that should be performed before the model is flown. To help avoid this, a check list is provided to make sure these important areas are not overlooked. Many are covered in the instruction manual, so where appropriate, refer to the manual for complete instructions. Be sure to check the items off as they are completed.

- 1. Fuelproof all areas exposed to fuel or exhaust residue such as the wing saddle area, etc.
- 2. Check the C.G. according to the measurements provided in the manual.
- 3. Be certain the battery and receiver are securely mounted in the fuselage. Simply stuffing them into place with foam rubber is not sufficient.

- 4. Extend your receiver antenna and make sure it has a strain relief inside the fuselage to keep tension off the solder joint inside the receiver.
- 5. Balance your model *laterally* as explained in the instructions.
- 6. Use thread locking compound to secure critical fasteners such as the screws that hold the wheel collars to the axles, screws that hold the carburetor arm (if applicable), screw-lock pushrod connectors, etc.
- 7. Add a drop of oil to the axles so the wheels will turn freely.
- 8. Make sure all hinges are **securely** glued in place.
- 9. Reinforce holes for wood screws with thin CA where appropriate (servo mounting screws, etc.).
- 10. Confirm that all controls operate in the correct direction and the throws are set up according to the manual.
- 11. Make sure there are silicone retainers on all the clevises and that all servo arms are secured to the servos with the screws included with your radio.
- 12. Secure connections between servo wires or servo extensions, and the connection between your battery pack and the on/off switch with vinyl tape, heat shrink tubing or special clips suitable for that purpose.
- 13. Make sure any servo extension cords you may have used do not interfere with other systems (servo arms, pushrods, etc.).
- 14. Secure the pressure tap (if used) to the muffler with high temp RTV silicone, thread locking compound or J.B. Weld.
- 15. Make sure the fuel lines are connected and are not kinked.
- 16. Balance your propeller (and spare propellers).
- 17. Tighten the propeller nut and spinner.
- 18. Place your name, address, AMA number and telephone number on or inside your model.
- 19. Cycle your receiver battery pack (if necessary) and make sure it is fully charged.
- 20. If you wish to photograph your model, do so before your first flight.
- 21. Range check your radio when you get to the flying field.

### GETTING READY TO FLY

You have put a lot of effort into assembling your model and it looks great! Protect your investment by following a few simple tips:

- 1. If possible, have an experienced modeler look over your work before you head out to your flying field. It's easier to fix problems in the workshop instead of on the flight line. It is also highly recommended to obtain help from an experienced modeler to act as a flight instructor. It is possible to teach yourself to fly a radio controlled model, but you will have a much more pleasant experience and incur a lot less damage to your first model with the help of a qualified flight instructor.
- 2. Become familiar with starting your engine, and break it in before your first flight. Be sure the engine will stop when the trim lever is pulled all the way back.
- 3. Assemble a simple flight kit which should include a starting battery and a glow-plug clip (or ni-starter), "chicken stick" for

flipping the prop, fuel and a means of filling the tank, a couple of small screwdrivers, #64 rubber bands, spare prop and glow plug, 6" adjustable wrench, and a pair of needle nose pliers. In addition to tools, you should also take along some paper towels and spray window cleaner to remove fuel residue after each flight.

4. When you load up to go to the flying field be sure that the batteries have charged for at least 14 hours, and that you have your fuselage, wing, transmitter and flight box. And, most important, you have your AMA license.

5. Range check the radio! See the manufacturer's instructions included with your radio system.

### Using Rubber Bands

Mount the wing to the fuselage with the 12 supplied rubber bands. Install them from front to back, crisscrossing the last two. Never use torn, cracked or oily rubber bands. After removing the rubber bands from your model, store them in a container with talcum powder or clay-type kitty litter to absorb oil and keep them fresh for the next flying session.

If the rubber bands you will be using are different from those recommended, consult an experienced modeler to make certain they are strong enough, and that you have used enough of them. If uncertain, force the front of the wing off of the wing saddle. There should be considerable resistance! If the wing can be forced from the fuselage without having to strain your hands, then there are probably not enough rubber bands.

**IMPORTANT!!!** *Flying a model with too few rubber bands can be dangerous. If the wing momentarily lifts from the fuselage and acts as though a large amount of "up" elevator has suddenly been applied because there are not enough rubber bands or they are too weak, internal structural damage may result. Even worse, the wing could actually detach from the fuselage resulting in a crash. If the model exhibits any tendencies that indicate there are not enough rubber bands, immediately reduce power, land and closely inspect the model for damage. If no damage is found, add more rubber bands.*

### Taxiing

Start the engine and set the throttle trim for a slow, steady idle. Have your instructor or a helper hold the plane while you work the controls. Upon release of the plane, advance the throttle slightly to start rolling, and then back off the power to prevent going too fast and possibly taking off. Stand behind the plane as it taxis away from you and note the direction it turns as you move the rudder control. One thing to keep in mind with R/C models (whether it be cars, boats, or planes) is that the steering controls may seem to "reverse" when the model is moving toward you. For example, if you are flying toward yourself, and you give a right control input (ailerons or rudder), the model will move off to your left. The fact of the matter is, of course, that the controls are not reversed and the aircraft did actually enter a

right turn. The plane does move off to your left from your vantage point, but if you imagined yourself in the cockpit you would realize the plane turned to the right as commanded. All it takes is a little practice to maintain proper orientation of your aircraft, but that's why we recommend finding an instructor.

When you feel comfortable, advance the throttle a little while standing behind the plane to get the feel of a takeoff roll, but pull back on the power before the model lifts off. Try this several times, adding a little more power each time. Use the rudder stick on your transmitter to steer the plane with the nose wheel while on the ground. If the plane starts to veer off, immediately cut the power to prevent a mishap.

Although many R/C pilots have taught themselves to fly, we strongly recommend that you find an instructor to help get you started. Although trainers offer the greatest opportunity of success for the self-taught, there is a high probability that you will crash your airplane on the first flight. Protect your investment of time and money—obtain the assistance of an experienced R/C pilot.

### Takeoff

Your first flight should be made in little or no wind. If you have dual rates on your transmitter, set the switches to "low rate" for takeoff. Taxi into position, pointing directly into the wind. Although this model has good low speed characteristics, you should always gain as much speed as your runway will permit before lifting off, as this will give you a safety margin in case of a "flame-out." Advance the throttle smoothly to the wide-open setting. When the plane has sufficient flying speed (you won't know until you try), lift off by smoothly applying a little up elevator (don't force it off into a steep climb!), and climb out gradually, trying to keep it straight and the wings level. Climb to about 100 feet before starting a VERY gentle turn by moving the aileron stick. Apply a little more back pressure on the elevator stick as the model turns. Stop the turn by moving the aileron stick in the opposite direction until the wings are level, then return the stick to the neutral position. Pull the power back to 1/2 throttle.

### Flying

We recommend that you take it easy with your model for the first several flights and gradually "get acquainted" with the plane as your engine becomes fully broken-in. Trainers are designed to fly level with neutral elevator trim at approximately 1/3 - 1/2 throttle – this is the best speed for learning to fly. On later flights, if you want your model to maintain level flight at full throttle, you will need to give it a little down trim.

Your first flights should consist of mostly straight and level flight with gentle turns to keep the model over the field. These flights will give you practice at coordinating your control inputs and maintaining the proper orientation of the airplane. As mentioned earlier, turns are accomplished by banking the aircraft with the ailerons, then gently adding some back stick (up elevator). Enough back stick should be held in to keep the aircraft at a constant altitude. To stop turning, apply opposite aileron to level

the wings, then release the stick. There is a memory aid that may help keep you out of trouble when the plane is flying toward you – “put the stick under the low wing.” In other words, move the aileron stick in the direction of the low wing to raise that wing. When you are comfortable flying the aircraft, you can practice using the rudder along with the ailerons to “coordinate” the turns – usually, a small amount of rudder applied in the direction of the turn will keep the tail following in the exact same track as the nose.

The most common mistake when learning to fly is “over control.” Think of pressure instead of large movements of the control sticks. Remember, most trainers will recover from almost any over control situation (given enough altitude) if you simply let go of the sticks.

Add and practice one maneuver at a time, learning how your model behaves in each one. For ultra-smooth flying and normal maneuvers, we recommend using the “low-rate” settings. High rate control throws will give your model enough control for loops, barrel rolls, and many other basic aerobatic maneuvers.

## Landing

When it's time to land, fly a normal landing pattern and approach as follows: Reduce the power to about 1/4 throttle and fly a downwind leg far enough out from the runway to allow you to make a gentle 180° turn. As you make the turn into the wind for your final approach, pull the throttle back to idle. Most trainer planes have a lot of lift, so you will need a slow, reliable idle in order to achieve a nice, slow landing. Allow the plane to keep descending on a gradual glide slope until you are about 3 feet off the runway. Gradually apply a little up elevator to flare for landing. You should apply just enough up elevator to hold the plane just off the runway while the excess speed bleeds off. The model should settle onto the runway for a slow, slightly nose-high landing.

After you have several flights on your model, it's time to reward yourself with your first aerobatic maneuver – a loop. Climb to a safe altitude and turn into the wind. Apply full throttle, level the wings, then slowly pull back on the elevator stick to about 1/2 to 3/4 up elevator (depending on your throws), and hold this control input. After you go over the top and start down the backside of the loop, pull the throttle back to about half. This will keep the stresses on the airplane low and the airspeed relatively constant. Keep holding “up” elevator until the plane is level, and then slowly release the stick. You're done! It's really that easy!

## FUEL MIXTURE ADJUSTMENTS

The fuel mixture should be richened so the engine runs at about 200 rpm below peak speed. By running the engine slightly rich, you will help prevent dead-stick landings caused by overheating and will keep your engine lubricated well during the break-in period.

**CAUTION (THIS APPLIES TO ALL R/C AIRPLANES):** If, while flying, you notice any unusual sounds, such as a low-pitched “buzz,” this may indicate control surface *flutter*. Because flutter can quickly destroy components of your airplane, any time you detect flutter you must **immediately** cut the throttle and land the airplane! Check all servo grommets for deterioration (this may indicate which surface fluttered), and make sure all pushrod linkages are secure and free of play. If the control surface fluttered once, it probably will flutter again under similar circumstances unless you can eliminate the free-play or flexing in the linkages. Here are some things which can cause flutter: Excessive hinge gap; Not mounting control horns solidly; Poor fit of clevis pin in horn; Side-play of pushrod in guide tube caused by tight bends; Excessive *play* or *backlash* in servo gears; and Insecure servo mounting.

**Have a ball! But always stay in control and fly in a safe manner.**

**GOOD LUCK AND GREAT FLYING!**

## MODELING TERMS & TRIVIA

**Adverse Yaw** - The tendency of an airplane to yaw in the opposite direction of the roll. For instance, when right aileron is applied, the airplane yaws to the left, thus opposing the turn. Adverse yaw is common in trainer type airplanes having flat bottom wings. It is most noticeable at slow speeds and high angles of attack, such as during takeoffs and when stretching a landing approach. Caused by the unequal drag of the upward and downward deflection of the ailerons, this undesirable trait can be minimized by setting up the ailerons with Differential Throw or by coordinating the turns, using the aileron and rudder controls simultaneously. (See Differential Throw.)

**Ailerons** - Hinged control surfaces located on the trailing edge of the wing, one on each side, which provide control of the airplane about the roll axis. The control direction is often confusing to first time modelers. For a right roll or turn, the right hand aileron is moved upward and the left hand aileron downward, and vice versa for a left roll or turn.

**Angle of Attack** - The angle that the wing penetrates the air. As the angle of attack increases so does lift and drag, up to a point.

**ARF** - A prefabricated model - Almost Ready to Fly.

**Buddy Box** - Two similar transmitters that are wired together with a “trainer cord.” This is most useful when learning to fly — it's the same as having dual controls. The instructor can take control by using the “trainer switch” on his transmitter.

**CA** (Abbreviation for “Cyanoacrylate”) - An instant type glue that is available in various viscosities (Thin, Medium, Thick, and Gel). These glues are ideal for the assembly of wood

airplanes and other materials. **Note:** Most CA glues will attack Styrofoam.

**Carburetor** - The part of the engine which controls the speed or throttle setting and lean/rich mixture via setting of the needle valve.

**CG** ("Center of Gravity") - For modeling purposes, this is usually considered – the point at which the airplane balances fore to aft. This point is critical in regards to how the airplane reacts in the air. A tail-heavy plane will be very snappy but generally very unstable and susceptible to more frequent stalls. If the airplane is nose heavy, it will tend to track better and be less sensitive to control inputs, but, will generally drop its nose when the throttle is reduced to idle. This makes the plane more difficult to land since it takes more effort to hold the nose up. A nose heavy airplane will have to come in faster to land safely.

**Charge Jack** - The plug receptacle of the switch harness into which the charger is plugged to charge the airborne battery. An expanded scale voltmeter (ESV) can also be plugged into it to check battery voltage between flights. It is advisable to mount the charge jack in an accessible area of the fuselage so an ESV can be used without removing the wing.

**Charger** - Device used to recharge batteries and usually supplied with the radio if NiCd batteries are included.

**Chicken Stick** - A hand-held stick used to "flip start" a model airplane engine.

**Clunk** - A weighted fuel pick-up used in a fuel tank to assure the intake line is always in fuel.

**Dead Stick** - A term used to describe unpowered flight (glide) when the engine quits running.

**Differential Throw** - Ailerons that are set up to deflect more in the upward direction than downward are said to have Differential Throw. The purpose is to counteract Adverse Yaw.

**Dihedral** - The V-shaped bend in the wing. Typically, more dihedral causes more aerodynamic stability in an airplane, and causes the rudder to control both the roll and yaw axis. This is why some trainers and sailplanes require only 3 channels of radio control—i.e., having no ailerons.

**Ding** - Minor dent or damage to the structure. Also, a nick in a prop. Dinged props must be replaced.

**Down Thrust** - Downward angle of the engine relative to the centerline of the airplane. Down thrust helps overcome the normal climbing tendency of flat bottom wings.

**Electric Starter** - A hand-held electric motor used for starting a model airplane engine. Usually powered by a 12-volt battery.

**Elevator** - Hinged control surface located at the trailing edge of the horizontal stabilizer, which provides control of

the airplane about the pitch axis and causes the airplane to climb or dive. The correct direction of control is to pull the transmitter elevator control stick back, toward the bottom of the transmitter, to move the elevator upward, which causes the airplane to climb, and vice versa to dive.

**Epoxy** - A two-part resin/hardener glue that is extremely strong. It is generally available in 6 and 30-minute formulas. Used for critical points in the aircraft where high strength is necessary.

**Expanded Scale Voltmeter (ESV)** - Device used to read the battery voltage of the on-board battery pack or transmitter battery pack.

**Field Charger** - A fast battery charger designed to work from a 12-volt power source, such as a car battery.

**Flaps** - Hinged control surface located at the trailing edge of the wing inboard of the ailerons. The flaps are lowered to produce more aerodynamic lift from the wing, allowing a slower takeoff and landing speed. Flaps are often found on scale models, but usually not on basic trainers.

**Flare** - The point during the landing approach in which the pilot gives an increased amount of up elevator to smooth the touchdown of the airplane.

**Flight Box** - A special box used to hold and transport all equipment used at the flying field.

**Flight Pack** (or Airborne pack) - All of the radio equipment installed in the airplane, i.e., Receiver, Servos, Battery, Switch Harness.

**Flutter** - A phenomenon whereby the elevator or aileron control surface begins to oscillate violently in flight. This can sometimes cause the surface to break away from the aircraft and cause a crash. There are many reasons for this, but the most common are excessive hinge gap or excessive "slop" in the pushrod connections and control horns. If you ever hear a low-pitched buzzing sound, reduce throttle and land immediately.

**Frequency Control** - The FCC has allowed the 72MHz band to be used for R/C aircraft operations. This band is divided up into many different channels in which you can choose a radio system. You should be aware that certain areas have frequencies in which there is pager interference. This is why it is always a wise move to check with your local hobby shop to find out any channels that may be troublesome in the area you wish to fly.

**Fuel Overflow Line (Vent)** - The fuel line is either open to atmospheric pressure or attaches to the muffler pressure nipple to pressurize the fuel tank for better fuel flow to the engine. This is the line through which the fuel will overflow when the tank is full.

**Fuel Pick Up-Line** - The fuel line in the fuel tank through which fuel travels to the carburetor. Typically a flexible tube

with a weight or “Clunk” on the end which allows it to follow the fuel with changes in aircraft attitude. This is the line through which the tank is filled.

**Fuselage** - The body of an airplane.

**Glitch** - Momentary radio problem that never happens unless you are over trees or a swamp.

**Glow Plug** - The heat source for igniting the fuel/air mixture in the engine. When starting the engine a battery is used to heat the filament. After the engine is running, the battery can be removed. The wire filament inside the plug is kept hot by the “explosions” in the engine’s cylinder. (See next heading and “Idle Bar” Plug.)

**Glow Plug Clip/Battery** - A 1.2-volt battery, which is connected to the glow plug on a model airplane engine for starting. The battery is removed once the engine is running steadily.

**Grease-In** - A very smooth, gentle landing without a hint of a bounce.

**Hit** (or to be hit) - Sudden radio interference which causes your model to fly in an erratic manner. Most often caused by someone turning on a radio that is on your frequency, but can be caused by other radio sources miles away.

**Horizontal Stabilizer** - The horizontal tail surface at the back of the fuselage which provides aerodynamic pitch stability to the airplane.

**Idle Bar Plug** - This type of glow plug has a “bar” across the tip to help prevent raw fuel from being splashed onto the glow element. Too much raw fuel will cool the plug and prevent it from igniting the fuel/air mixture. An idle bar is a help in obtaining a low idle speed.

**Lateral Balance** - The left-right or side-to-side balance of an airplane. An airplane that is laterally balanced will track better through loops and other maneuvers.

**Leading Edge** (LE) - The very front edge of the wing or stabilizer. This is the edge that hits the air first.

**Muffler** - A device attached to the exhaust stack of the engine to reduce noise and increase back pressure which helps low speed performance. **Note:** Most R/C Clubs require the use of mufflers.

**Muffler Baffle** - A restrictor plate inside the muffler which reduces engine noise. This plate can be removed to increase power, but only if there are no noise restrictions where you fly.

**Needle Valve** - Adjustment on a carburetor used to set proper fuel/air mixture. Some carburetors have separate needle adjustments for low and high throttle. Typically, turning the needle clockwise (threading in) leans the mixture (less fuel), and vice versa. However, there are a few exceptions—refer to the engine manufacturer’s instructions.

**NiCd** - Nickel Cadmium battery. Rechargeable batteries which are typically used as power for radio transmitters and receivers.

**Nitro** - Nitromethane, a fuel additive which increases a model engine’s ability to idle low and improves high speed performance. Ideal nitro content varies from engine to engine. Refer to the engine manufacturer’s instructions for best results. Nitro content in fuel is indicated by the percent of the fuel.

**Ni-Starter** - A self-contained battery and glow plug clip, used when starting the engine. (See Glow Plug Clip.)

**Pitch Axis** - The airplane axis controlled by the elevator. Pitch is illustrated by holding the airplane at each wing tip. Raising or lowering the nose is the pitch movement. This is how the climb or dive is controlled.

**Prop Pitch** - Props are designated by these two numbers, for instance 10 - 6. The first number is the prop’s length, 10". The second number is the pitch or angle of the blades. The 6 represents the distance the propeller will move forward in one revolution, in this case 6".

**Receiver** (Rx) - The radio unit in the airplane which receives the transmitter signal and relays the control to the servos. This is somewhat similar to the radio you may have in your family automobile, except the radio in the airplane perceives commands from the transmitter, while the radio in your car perceives music from the radio station.

**Roll Axis** - The airplane axis controlled by the ailerons. Roll is illustrated by holding the airplane by the nose and tail. Dropping either wing tip is the roll movement. This is used to bank or turn the airplane. Many aircraft are not equipped with ailerons and the Roll and Yaw motions are controlled by the rudder. This is one reason why most trainer aircraft have a larger amount of dihedral.

**Rudder** - Hinged control surface located at the trailing edge of the vertical stabilizer, which provides control of the airplane about the Yaw axis and causes the airplane to Yaw left or right. Left rudder movement causes the airplane to Yaw left, and right rudder movement causes it to Yaw right.

**Servo** - The electro-mechanical device which moves the control surfaces or throttle of the airplane according to commands from the receiver. The radio device which does the physical work inside the airplane.

**Servo Output Arm** - The removable arm or wheel which bolts to the output shaft of a servo and connects to the pushrod.

**Shot Down** - A “hit” that results in a crash landing. Sometimes caused by radios miles away.

**Slop** - Unwanted, excessive free movement in a control system. Often caused by a hole in a servo arm or control horn that is too big for the pushrod wire or clevis pin. This condition allows the control surface to move without transmitter stick movement. (See Flutter.)

**Solo** - Your first totally unassisted flight that results in a controlled landing.

**Spinner** - The nose cone, which covers the propeller hub.

**Sport Airplane** - A model which possesses some attributes of many of the specialty airplanes and are best for general flying as they are the most versatile and durable.

**Stall** - What happens when the angle of attack is too great to generate lift regardless of airspeed. (Every airfoil has an angle of attack at which it generates maximum lift — the airfoil will stall beyond this angle).

**Tachometer** - An optical sensor designed specifically to count light impulses through a turning propeller and read out the engine RPM.

**Tip Stall** - The outboard end of one wing (the tip) stops developing lift, causing the plane to roll suddenly in the direction of the stalled wing. This situation is not fun when you are only a few feet off the runway trying to land.

**Trainer Airplane** - A model designed to be inherently stable and fly at low speeds, to give first-time modelers time to think and react as they learn to fly.

**Trailing Edge (TE)** - The rearmost edge of the wing or stabilizer.

**Transmitter (Tx)** - The hand-held radio controller. This is the unit that sends out the commands that you input.

**Touch-And-Go** - Landing and taking off without a pause. Often confused with a good bounce.

**Vertical Fin** - The non-moving surface that is perpendicular to the horizontal stabilizer and provides yaw stability. This is the surface to which the rudder attaches.

**Washout** - An intentional twist in the wing, causing the wing tips to have a lower angle of attack than the wing root. In other words, the trailing edge is higher than the leading edge at the wing tips. Washout helps prevent tip stalls.

**Wheel Collar** - A small, round retaining device used to keep wheels from sliding off an axle.

**Wing** - The main lifting surface of an airplane.

**Wing Loading** - This is the amount of weight per square foot that has to be overcome to provide lift. It is normally expressed in ounces per square foot. This specification can be easily calculated as follows: If you know the square inches of the wing, simply divide by 144 to obtain square feet. Divide the total weight (in ounces) of the airplane by the wing area (in square feet). This information is valuable when deciding on which airplane to build next. Planes with high wing loading numbers must fly faster to stay in the air. These are generally "performance" airplanes. Conversely, planes with lower numbers do not need as much air flowing around

the wing to keep it flying. Gliders and trainer airplanes fall into this category because slow, efficient flight is desirable.

**Wing Root** - The centerline of the wing, where the left and right wing panels are joined.

**Yaw Axis** - The airplane axis controlled by the rudder. Yaw is illustrated by hanging the airplane level by a wire located at the center of gravity. Left or right movement of the nose is the Yaw movement.

**Z-Bend** - A simple Z-shaped bend in the wire end of a pushrod, which is used to attach the pushrod to a servo output arm.

Fill out the ID tag below and tape it in your model.  
We have included a spare tag.

## PARTS LIST

Before assembly match the parts in the photo with the parts in the kit. Check off each part as it is located.  
If any parts are missing or damaged, consult Tower Hobbies Order Assistance (see phone numbers listed on front page).  
**Note:** All parts are one per kit unless otherwise stated.

This model belongs to:

Name \_\_\_\_\_

Address \_\_\_\_\_

City, State Zip \_\_\_\_\_

Phone number \_\_\_\_\_

AMA number \_\_\_\_\_

This model belongs to:

Name \_\_\_\_\_

Address \_\_\_\_\_

City, State Zip \_\_\_\_\_

Phone number \_\_\_\_\_

AMA number \_\_\_\_\_

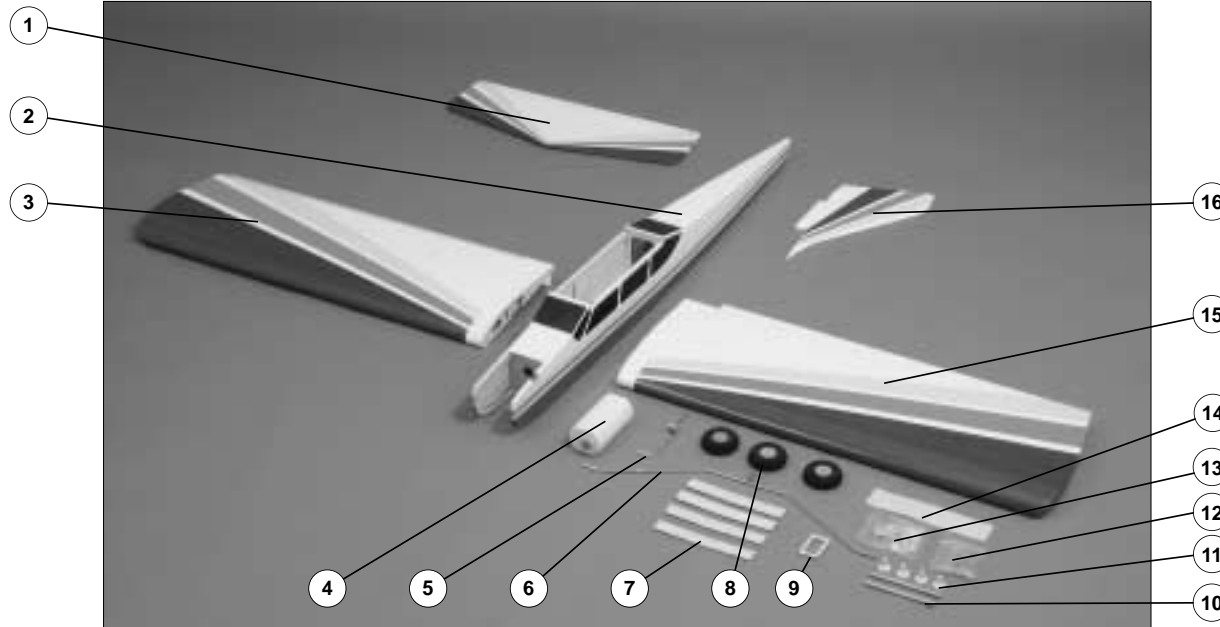

### Parts List

- 1. Stabilizer/Elevator
- 2. Fuselage
- 3. Right Wing Panel w/Aileron
- 4. Fuel Tank
- 5. Nose Landing Gear
- 6. Main Landing Gear (2 pcs.)
- 7. Wing Joiners
- 8. Wheels (3)
- 9. Aileron Servo Tray
- 10. Wing Dowels (2 pcs.)
- 11. Molded Wing Dowel Covers (4 pcs.)
- 12. Hardware Bag
- 13. Plastic Parts Bag
- 14. Hook and Loop Material
- 15. Left Wing Panel w/Aileron
- 16. Rudder/Fin

### Hardware and Plastic Bag Contents

- (12) Rubber Bands
- (2) Aileron Servo Tray Mounting Blocks
- (1) Receiver/Battery Tray
- (2) Aileron Pushrods
- (2) Pushrods for Elevator and Rudder
- (1) Pushrod for Nose Wheel Steering
- (1) Pushrod for Throttle
- (2) Outer Plastic Tubes for Throttle/Steering Pushrods
- (2) Protective Foam for Receiver and Battery
- (1) Engine Mount, .60-Size
- (2) Landing Gear Straps
- (4) 4mm x 25mm Screws
- (8) Lock Washers
- (4) 4mm Nuts
- (4) 4mm x 20mm Screws
- (2) 4mm x 12mm Screws
- (2) 4mm Flat Washers
- (4) 4mm Wheel Collars for Nose Wheel, Steering Arm, and Nose Gear
- (4) 5mm Wheel Collars for Main Wheels
- (7) 3mm x 5mm Screws
- (1) 3mm x 8mm Screw
- (2 sets) Screw-Lock Pushrod Connectors
- (4) 3mm x 10mm Screws
- (8) 2.6mm x 8mm Screws
- (4) 2mm x 14mm Screws
- (1) Nose Wheel Steering Arm
- (1) Nose Wheel Bearing Block
- (14) CA Hinges
- (2 sets) Control Horns
- (5) Clevises
- (4) Nylon Faslinc Keepers
- (5) Silicone Clevis Keepers
- (2) Engine Mounting Straps
- (2) Nylon Aileron Torque Rod Control Horns
- (1) Spinner
- (1) Fuel Tubing, 305mm long

### Ordering Replacement Parts

Replacement parts are available from Tower Hobbies for your Tower Trainer 60 MKII ARF. Our order assistance representatives are ready to answer your questions or to place your order. Call us at (800) 637-6050 or e-mail us at:

[www.productsupport@towerhobbies.com](mailto:www.productsupport@towerhobbies.com)

### Replacement Parts

Order Number	Description
TOWA2065	Wing Set
TOWA2066	Fuselage Set
TOWA2067	Tail Surface Set
TOWA2068	Landing Gear

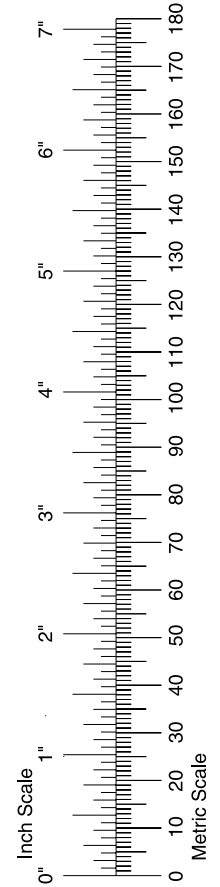



### Hobbico® DC Quick Field Charger (HCAM3000)

Fast-charge radio batteries anywhere.

Recharge 9.6V transmitter and 4.8V or 6.0V receiver batteries right on the spot, using any 12V DC input. Advanced Delta peak sensing technology automatically switches to trickle once batteries are fully charged. Unique voltage boost circuitry peaks transmitter NiCds even in diode-equipped radios. Includes 2.5A fuse, alligator clips on a 14" input cord and banana plugs. 2-year warranty. Connectors required.



### Tower Hobbies® 4-TH 4-Channel FM (TOWJ41\*\*)

With the 4-channel 4-TH, you'll take advantage of today's best FM technology. The 4-TH is all-NiCd, with all-channel servo reversing, mechanical trims for all four channels, Futaba®-compatible J plugs and a retractable, removable antenna. Gimbal stick length is adjustable and all controls are in easy reach. The built-in trainer system is compatible with most FM radios. Requires servos. Backed by a generous 1-year warranty. 72MHz.



### Tower Hobbies® TS-53 Standard Servo (TOWM4525)

Cutting-edge quality for precision and power.

**Torque:** 42 oz-in      **Speed:** .22 sec @ 60°  
**Weight:** 1.5 oz      **Dimensions:** 0.77"x1.59"x1.41"

System 3000 TS-53 Servos offer exceptional strength and dependability. Vibration-resistant Surface Mount Technology keeps them operating perfectly in the thick of action. They also feature impact-resistant, fuelproof cases - and universal connectors, compatible with Futaba®, JR®, Hitec® and all "Z" connector-equipped Airtronics systems, as well as all Tower systems. Includes ball bearings, complete mounting hardware, and warranty protection for one year.

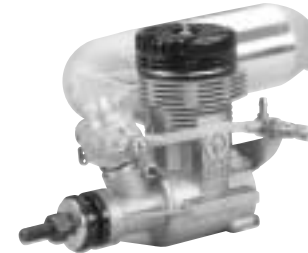

### Tower Hobbies® .61 ABC RC Engine (TOWG0161)

**Weight (w/muffler):** 23.8 oz      **Practical RPM Range:** 2,000-17,000  
**BHP @ RPM:** 1.9 @ 16,000

Tower's .61 ABC engine is perfectly suited for the Tower Trainer .60 MKII, offering power, economy, easy operation, and the reliability you need for trouble-free flying. Features include CNC-manufactured parts, true ABC piston/liner, Schnuerle porting, remote-mounted needle valve, muffler with pressure tap and rotatable exhaust outlet. Requires glow plug and prop. 2 year warranty plus postage-free parts support.